

SIGNUM KNX pushbutton with touch display

Codes: EK-EV2-TP-... (Deep)

EK-EV2-TP-S-... (Surface)



Datasheet STEKEV2TP_EN

KNX standard “virtual” button, based on a borderless IPS touch display, in which each button can be customized via a dedicated app. It is possible to change some attributes of each key even after installation, such as position, symbols and texts.



Description

The EK-EV2-TP pushbutton with touch display of the ekinex® SIGNUM series is a KNX device for the on / off control of utilities, the dimming of lighting devices, the control of motorized drives or other programmable command and control functions. The integrated temperature sensor also allows it to be used as a temperature controller for an environment or area. The device is intended for KNX standard home and building automation systems, and it is equipped with a KNX bus communication module and is designed for wall installation on a round or square flush mounting box, equipped with fixing holes with 60 mm center distance. The button must be completed with a plate from the Deep or Surface series. The 2.65", 162 x 320 pixel 262K color borderless IPS touch display with haptic feedback can be configured to manage up to 4 buttons per page and up to 3 total pages. Each button can be customized via the dedicated Ekinex Tool app via BLE

(Bluetooth Low Energy) and it is possible to change some attributes of each button even after installation, such as symbols and text. The proximity sensor integrated into the plate (to be ordered separately) allows the activation of the backlight and other functions, guarantees maximum readability when using the pushbutton and allows visual comfort during the night. The device is powered at SELV 30 Vdc voltage by means of the KNX bus and does not require auxiliary power supply.

Main functional characteristics

- On/off switching of single loads or groups of loads
- Dimming of lighting devices
- Control of motor drives (for roller shutters, blinds, curtains, etc.)
- Measuring and regulation of room temperature via integrated sensor
- Backlight activation and other functions by means of an integrated proximity sensor
- Logic functions
- Switching to forced operation (lock)
- Recall and memorization of scenarios
- Different programmable functions for short press / long press of a button
- Touch display with haptic feedback
- Programming via Bluetooth with iOS 9.1 or Android 5.1 and higher apps
- Possibility to configure up to 12 buttons arranged on 3 pages, with a dedicated page for thermostat functions
- Customizable buttons with text or icons
- Graphic display of the thermostat function that can be enabled via voucher
- Graphical interface for controlling audio sources, which can be enabled via voucher
- Integration with the KNX network via ekinex® Delégo supervision system or the ekinex® EK-BW1-TP voice assistant interface
- Front cover with proximity sensor, in the same metal finishes as in the catalog
- Compatibility and family feeling with the Ekinex 20venti series

Other characteristics

- Housing in plastic material
- Wall installation in flush mounting box
- Protection degree IP20 (installed device)
- Climatic 3K5 and mechanical 3M2 classification (according to EN 50491-2)
- Pollution degree 2 (according to IEC 60664-1)
- Weight 88 g (without mounting support)
- Dimensions 77 x 83 x 37 mm (LxHxP)

Technical data

- Power supply 30 Vdc from KNX bus line
- Current consumption from bus < 37 mA
- Max. power from bus < 1.1 W
- 2.65" IPS display, 162 x 320 pixels, 262K colors with haptic feedback

Environmental conditions

- Operating temperature: - 5 ... + 45°C
- Storage temperature: - 25 ... + 55°C
- Transport temperature: - 25 ... + 70°C
- Relative humidity: 95% not condensing

Delivery

The metal support for wall mounting box (cod. EK-SMQ-71-S), the fixing screws and the KNX terminal block for the connection to the power supply are delivered with the device.

Finishing plates and proximity sensor

The device has to be ordered with an ekinex® plate in metal (aluminum) or Metal HT (chromed), with a 30 x 60 mm window and integrated proximity sensor. The plate is available for Deep or Surface series mounting and can be ordered either with SIGNUM or separately.

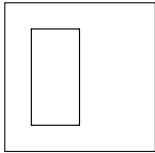

SIGNUM with square single plate and proximity sensor (*)
with 30 x 60 mm window
Code: EK-EV2-TP... (Deep version)
EK-EV2-TP-S... (Surface version)

(*) To be completed with the extension for colour and finishing



Note. The plate for completing the device can be ordered with the SIGNUM pushbutton or separately. For more information on available materials, colours and finishes, see also the ekinex® product catalog or browse www.ekinex.com.

Mounting

The device has degree of protection IP20, and is therefore suitable for use in dry interior rooms. The installation of the device can be done with round or square flush mounting box.

To mount the device, please carry out the following operations:

Deep series

- fix the metal support (e) by means of the pair of screws (d) on the flush mounting box (g) equipped with suitable holes;
- insert the device (b1) into the support-box assembly (e+g), inserting the bus terminal, previously connected to the bus cable (see: "Connection to the KNX bus line"), in the appropriate seat on the back of the device;
- screw the device (b1) onto the support-box assembly (e+g) using the pair of screws (c) supplied;
- mount the plate (a), by inserting it from the opposite side to that of the proximity sensor (highlighted by the slot) and pressing slightly in the sensor area for closure.

Surface series

- fix the plastic adapter (f) by means of the pair of screws (d) on the flush mounting box (g) equipped with suitable holes;
- hook the device (b2), previously fixed to the plate (a) with suitable screws, to the support-box assembly (f+g) using the magnets and inserting the bus terminal, previously connected to the bus cable (see: "Connection to the KNX bus network"), in the special housing on the back of the device.



Note. The screws supplied in the package are suitable for standard installations. For more specific applications, where the screws have to be replaced, only flat-head screws must be used. The screws for the metal support must be tightened with a max. torque of 1.0 Nm.

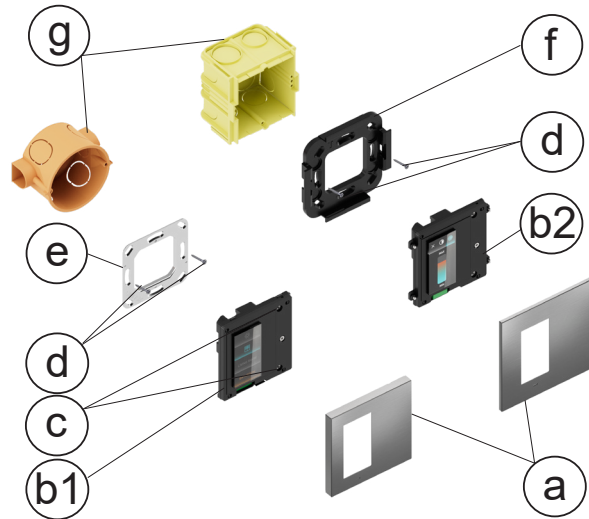

Installation for Deep or Surface series

- a) Deep or Surface series plate (to be ordered separately)
- b1), b2) EK-EV2-TP "SIGNUM" pushbutton
- c) Screws for fixing the device on the support (Deep series only, included in the delivery)
- d) Fixing screws for metal support (Deep) or plastic adapter (Surface) on wall mounting box (supplied)(included in the delivery)
- e) Metal support for wall mounting box (Deep series only, included in the delivery)
- f) Adapter in plastic material with magnets for wall mounting box (Surface series only, included in the delivery)
- g) Wall mounting box (not delivered by ekinex)

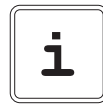

Note. The device can be mounted with the window on the right side, by rotating both the pushbutton and the plate by 180°. In this case, the proximity sensor and its slot will be located in the upper part of the panel, instead of at the bottom.

Mounting position

If the integrated sensor is used for temperature regulation, the device has to be installed preferably on an internal wall at a height between 0.70 and 1.5 m and at least 0.3 m far from doors. The device can not be installed close to heat sources such as radiators or household appliances or in position subjected to direct sunlight. If necessary, for the regulation can be used a weighted average between the value measured by the integrated sensor and a value received via bus by another KNX device.

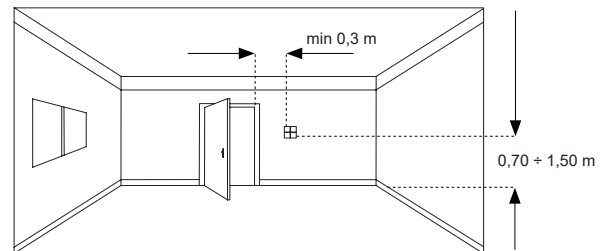

Main functional characteristics (thermostat function)

- Temperature measurement using the integrated sensor with the possibility of sending the value on the bus
- 2-point room temperature adjustment (ON/OFF type) or proportional (PWM or continuous)
- Conduction modes: heating and cooling with the possibility of switching via bus or automatic based on the configured operating logic
- Operating modes: comfort, standby, economy and building protection with separate setpoints for heating and cooling operation
- Automatic switching of the operating mode according to window opening function
- Weighted average of two temperature values
- Temperature control alarm
- Valve anti-blocking function (for hydronic systems)

Switching and display elements

The device is equipped with a IPS touch display for activating the functions of the pushbutton and a proximity sensor integrated in the front cover for activating the backlight and other programmable functions.

Switching elements

The touch display (1) can implement up to 12 buttons arranged on 3 pages, with a dedicated page for thermoregulation. The methods of interaction are as follows:

- touch or tap: pressing the area of a key with the finger for at least 15ms starts an activation or deactivation event;
- swipe: dragging the finger vertically from one side of the display to scroll through the function pages, while dragging it horizontally displays the settings and information pages;
- long press: prolonged touch (settable via ETS) of an area of the display activates the slider functions, such as light dimming or control of motor drives.

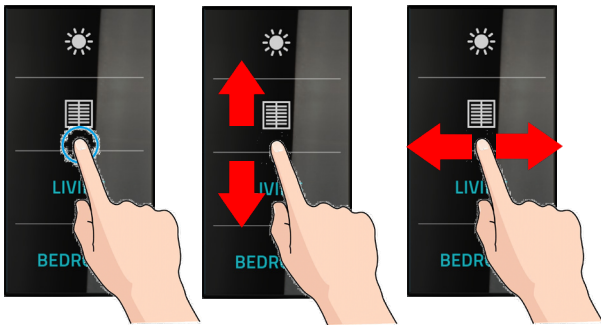

Touch / tap

Switching On / off, sending values or sequences, scenes

Long press

Slider activation for dimmer, up / down, modification of thermostat setpoint

Vertical swipe

Scrolling of function pages only

Horizontal swipe

Scroll through the pages of functions, info / programming / reset and settings

Display elements

IPS touch display with virtual buttons (1), with the possibility of customizing text and icons.

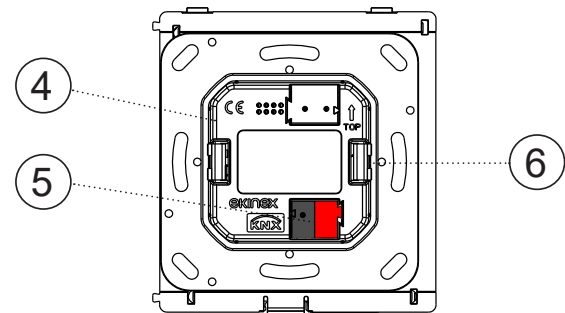
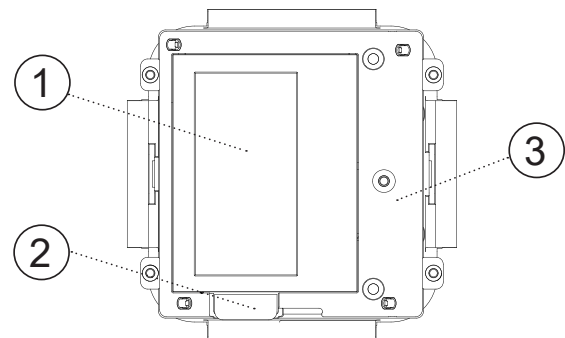
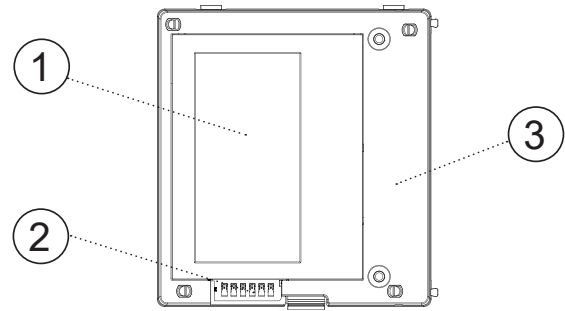

- 1) IPS touch display
- 2) Contacts for connecting the proximity sensor
- 3) Temperature sensor position (under the cover)
- 4) Product label
- 5) Terminal block for KNX bus line
- 6) Locking springs for metallic support

Connection of the KNX bus line

The power supply is connected via the 2-way terminal included in the device delivery. It has to be wired and inserted in the appropriate housing located on the back of the device (5), respecting the indicated polarity.



Warning! In order to supply the KNX bus lines use only KNX bus power supplies (e.g. ekinex EK-AB1-TP, EK-AG1-TP or EK-AM1-TP). The use of other power supplies can compromise the communication and damage the devices connected to the bus.

Characteristics of the KNX terminal block

- spring clamping of conductors
- 4 seats for conductors for each polarity
- terminal suitable for KNX bus cable with single-wire conductors and diameter between 0.6 and 0.8 mm (20-23 AWG)
- recommended wire stripping approx. 5 mm
- color codification: red = + (positive) bus conductor, black = - (negative) bus conductor
- Flammability rating: UL94-V0

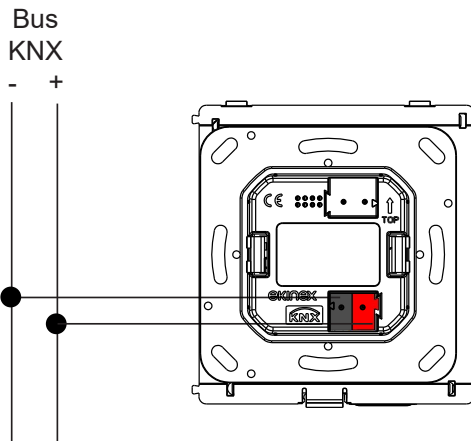

Warning! The electrical connection of the device can be carried out only by qualified personnel. The incorrect installation may result in electric shock or fire. Before making the electrical connections, make sure the power supply has been turned off.

Configuration and commissioning

Configuration and commissioning of the device require the use of the ETS® (Engineering Tool Software) program V4 or later releases. These activities must be carried out according to the design of the building automation system done by a qualified planner.



Note. The configuration and commissioning of KNX devices require specialized skills. To acquire these skills, you should attend the workshops at KNX certified training centers.

Configuration

To configure the SIGNUM parameters, the corresponding application program or the entire ekinex® product database must be loaded into the ETS® program. For detailed information on the parameterization, please consult the application manual of the device available on the website www.ekinex.com.

Commissioning

For the commissioning of SIGNUM, the following activities are required:

- make the electrical connections as described above;
- turn on the KNX bus power supply;
- switch the device operation to the programming mode by scrolling the display pages to the INFO page and pressing the PROGRAM virtual button for 5s, which will turn red;

- download the physical address and configuration into the device using the ETS® program.

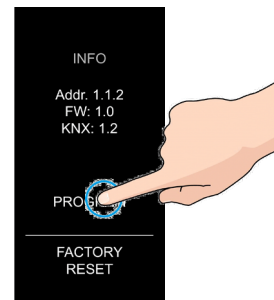

At the end of the download the operation of the device automatically returns to normal mode; in this mode all LEDs work as programmed. Now SIGNUM is programmed and ready for use.

Connection to the Ekinex Tool app

The user can customize some SIGNUM functions and attributes using the “Ekinex Tool” app, available for Android and iOS systems and downloadable from the related digital stores.



Note. The setup procedure requires the Bluetooth connection of the device (smartphone or tablet). If it is deactivated, the app will ask for its activation through the settings options.

The activities to be performed to connect to the app are as follows:

- scroll to the SETTING MODE page on the SIGNUM display; the device is now set to perform the pairing operation via Bluetooth;
- download and install the “Ekinex Tool” app, possibly framing the QR code with the smartphone;
- at the first start, follow the steps of the app wizard to add a new device, by pressing on the virtual symbol “+”; then, by pressing on “SIGNUM”, the configuration starts;
- End the procedure by following the steps, as described in the Ekinex Tool app guide.



Device reset

To reset the device, scroll the display pages to the INFO page and press the FACTORY RESET virtual button for a few seconds, until the brightness of the page lowers considerably.

The display will show the start page and the reset has been performed. At this point it is necessary to carry out the addressing and configuration of the device again via ETS®.

Il display visualizzerà la pagina di avvio e il reset è stato effettuato. A questo punto è necessario effettuare nuovamente l'indirizzamento e la configurazione del dispositivo mediante ETS®.



Warning! The reset restores the device back to the state of delivery from the factory. The address and the value of the parameters set during configuration will be lost.

Versions

Code	Version	Mounting
EK-EV2-TP	Deep	No frame
EK-EV2-TP-S	Surface	
Code	Voucher	
EK-EV2-V1-TER	Voucher to enable the graphic display of the thermostat function	
EK-EV2-V1-AUD	Voucher to enable the graphic display of the audio function	

Dimensions [mm]

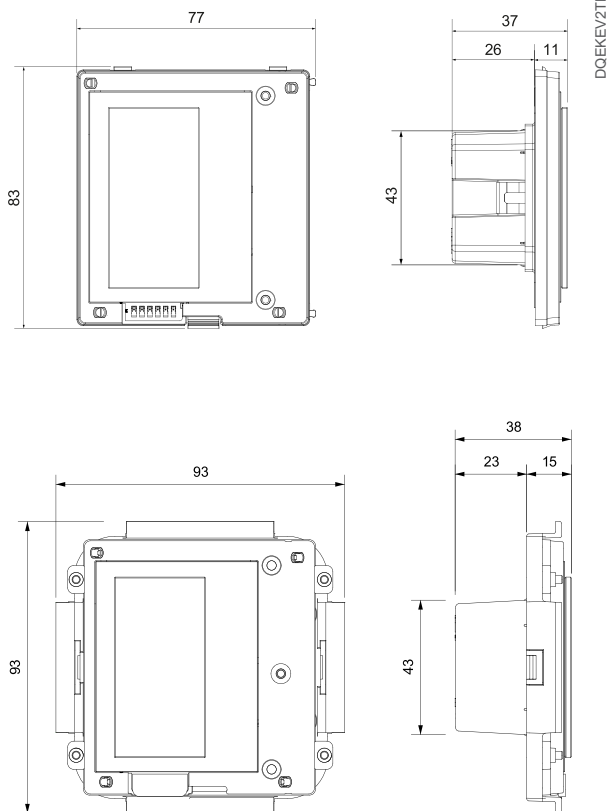

Marks

- KNX
- CE: the device complies with the Low Voltage Directive (2014/35/EU, the Electromagnetic Compatibility Directi-

ve (2014/30/EU), the RED (Radio Equipment Directive) 2014/53/UE and the RoHS 3 Directive (2015/863/EU). Tests carried out according to EN 63044-5-1:2019, EN 63044-5-2:2019.

Maintenance

The device is maintenance-free. To clean use a dry cloth. It must be avoided the use of solvents or other aggressive substances.

Disposal



At the end of its useful life the product described in this datasheet is classified as waste from electronic equipment in accordance with the European Directive 2012/19/EU (WEEE recast), and cannot be disposed together with the municipal undifferentiated solid waste.

Documentation

This datasheet refers to the release A1.0 of the ekinex® SIGNUM pushbuttons (codes EK-EV2-TP-... and EK-EV2-TP-S-...) and is available for download at www.ekinex.com as a PDF (Portable Data Format) file.

File name	Device release	Updating
STEKEV2TP_EN.pdf	A1.0	11 / 2022

Warnings

- Installation, electrical connection, configuration and commissioning of the device can only be carried out by qualified personnel in compliance with the applicable technical standards and laws of the respective countries
- Opening the housing of the device causes the immediate end of the warranty period
- In case of tampering, the compliance with the essential requirements of the applicable directives, for which the device has been certified, is no longer guaranteed
- ekinex® KNX defective devices must be returned to the manufacturer at the following address: EKINEX S.p.A. Via Novara 37, I-28010 Vaprio d'Agogna (NO) Italy

Other information

- This datasheet is aimed at installers, system integrators and planners
- For further information on the product, please contact the ekinex® technical support at the e-mail address: support@ekinex.com or visit the website www.ekinex.com
- Each ekinex® device has a unique serial number on the label. The serial number can be used by installers or system integrators for documentation purposes and has to be added in each communication addressed to the EKINEX technical support in case of malfunctioning of the device
- KNX® and ETS® are registered trademarks of KNX Association cvba, Brussels

© EKINEX S.p.A. The company reserves the right to make changes to this documentation without notice.

Annex 1. Installation

Ekinex® SIGNUM is a “virtual” button equipped with a KNX communication module. It is suitable for installation on a round or square wall mounting box, equipped with fixing holes with 60 mm center distance. The button must be completed with a plate of the Deep or Surface series. Each button is supplied with the metal support for mounting on the flush-mounting box (code EK-SMQ-71-S, which can also be ordered separately if necessary), the fixing screws, the desired plate and the connection terminal to the KNX bus line.

The cover plate is supplied in the Deep or Surface versions, with at least one 30x60 mm window, in the following finishes: metal, Metal HT (chromed) and Fenix NTM®, in numerous color variants.

The Fenix NTM® color effect on the Surface plate is obtained by painting.

The 2.65" borderless RGB touch IPS display, 162 x 320 pixels, 262K colors with haptic feedback can be configured to manage up to 4 keys per screen and up to 3 total pages. Each key can be customized via a dedicated app and it is possible to change some attributes even after installation, such as position, symbols and texts. The button also offers the functions of graphic display of the thermostat and control of audio sources, with activation via voucher.

The integrated proximity sensor integrated in the plate (to be ordered separately) allows visual comfort during the night.

The configuration and commissioning of the devices is carried out using the ETS® software; the related application programs can be downloaded from the website www.ekinex.com.

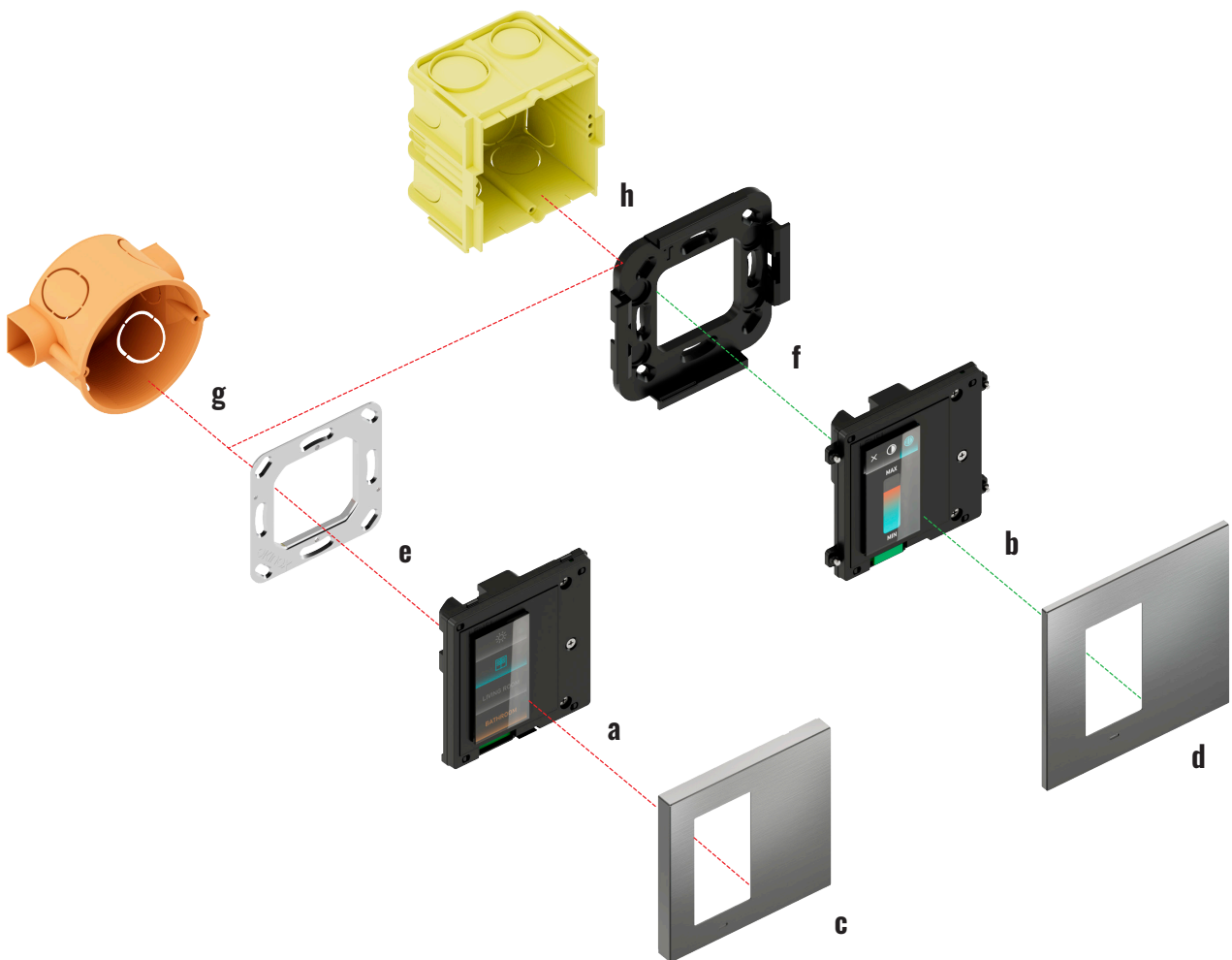

Legend

Description	Code
a) Deep version SIGNUM button	EK-EV2-TP-...
b) Surface version SIGNUM button	EK-EV2-TP-S-...
c) Deep version square plate (30 x 60 mm window)	EK-DQV-...
d) Surface version square plate (60 x 60 mm window)	EK-SQV-...
e) Deep version mounting metal support	EK-SMQ-71-F

Description	Code
f) Surface version mounting support (included in delivery)	-
g) Round flush-mounting box (not supplied by ekinex®)	-
h) Square flush-mounting box (not supplied by ekinex®)	-

Annex 2. SIGNUM pages

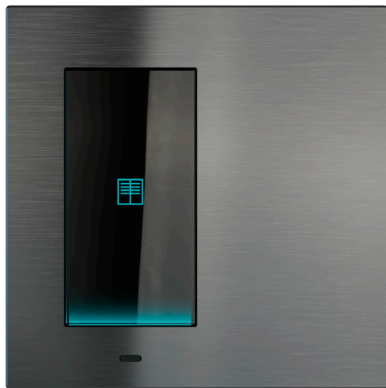

Page with 1 button

The extreme flexibility of SIGNUM panel allows you to arrange the buttons for each individual screen in 3 different ways: single button, double button and quadruple button.

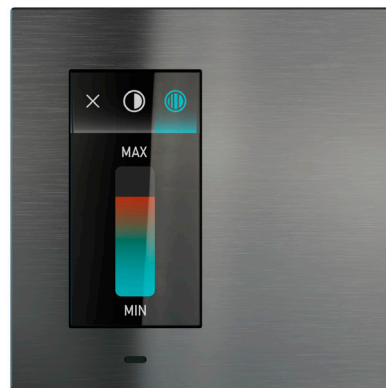

Color temperature setting page

It is possible to enable a page dedicated to controlling the tone of the light emitted by a light source, varying from a cold color to a warmer one.

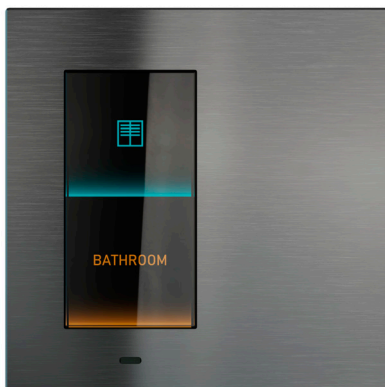

Page with 2 buttons

Each button can be customized with texts, symbols and colors.

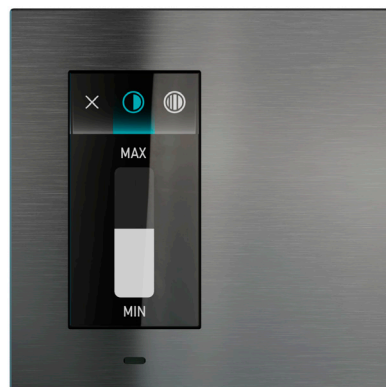

Brightness control page

The graphic slider allows for fine control of motorized or luminescent drives in percent.

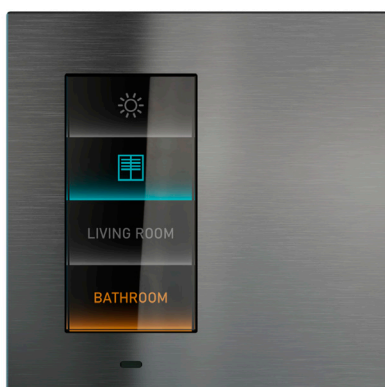

Page with 4 buttons

With the buttons it is possible to control lighting devices, scenarios and motorized drives. Holding it down can call up graphic pages for precision control of home automation elements.

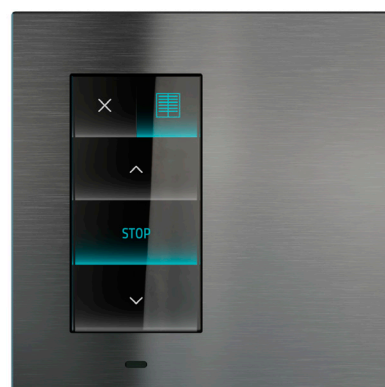

Motorisation control page

The motorisation page allows you to control motorised locking elements using the up and down buttons.



Room thermostat page

The thermostat page allows you to monitor the room temperature and control the desired temperature intuitively.

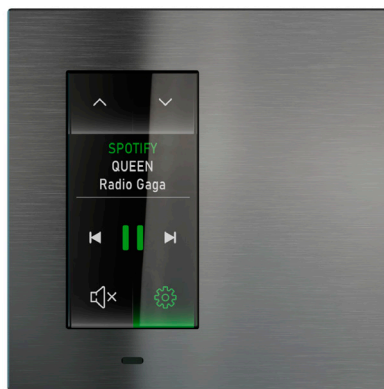

Audio page

The Audio page allows you to select an audio source, change the currently playing song, and increase or decrease the volume.

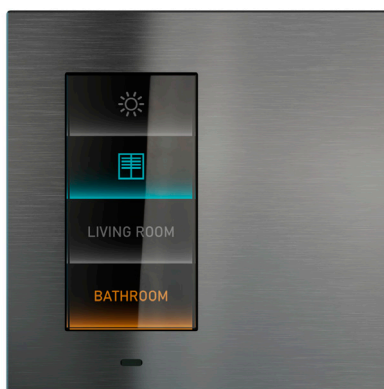

Audio settings page

The audio settings page allows you to control the volume level and the treble and bass equalization.