

Actuator / controller for electrothermal actuators

Code: EK-HE1-TP



Datasheet STEKHE1TP_EN

KNX device for control of electrothermal actuators for zone valves in heating and / or cooling systems. It has to be used in KNX installations for control of homes and buildings.



Description

The EK-HE1-TP actuator / controller is an ekinex® KNX S-mode bus device for the control of electrothermal actuators and / or motors for zone valves installed on distribution manifolds of installations with radiant panels or radiators. The 8 output channels use TRIAC to ensure a noiseless command and a high number of cycles. The device may work in combination with NC (normally closed) or NO (normally opened) actuators and may be used in installations with 2 or 4-pipe hydraulic distribution; in the latter application it is possible to interlock the outputs, completely closing the active valve before the opening of the coupled valve, avoiding the mix of heating and cooling conveying fluids. The device is provided with a membrane keypad for manual control of the outputs and LED indicators for the diagnosis of the operation state and of alarms triggered by short-circuit of the outputs or power failure. The device can be configured as simple actuator, in combination with one or more KNX room temperature controllers, or as actuator / controller with acquisition of max 2 temperature values from KNX room temperature sensors. The device integrates a KNX bus communication module and is realized for mounting on a standard 35 mm rail. The device is supplied by the KNX bus and requires an additional 230 Vac or 24 Vac power supply for the electrothermal actuators.

Functional characteristics

- 8 configurable channels for use with NC (normally closed) or NO (normally opened) electrothermal actuators
- Independent configuration of each output channel as actuator or actuator / controller for 2 or 4-pipe systems, channel in parallel or as simple controlled output through communication object

- Detection and reporting of short-circuit through monitoring of the current absorbed by the electrothermal actuators connected to the outputs
- Detection and reporting of lack of supply voltage on the electrothermal actuators connected to the outputs (only if supplied at 230 Vac)
- Selective single channel enabling for only one conduction mode. In systems with radiant floor panels, the function allows to simulate different steps of laying of the pipes depending on the conduction mode in order to achieve a higher cooling power
- Valve protection function (anti-seizure) during long periods of inactivity
- Delayed activation of the outputs (in the range 5-40 s) in order to avoid power-absorption peaks by the electrothermal actuators
- Automatic evaluation of the energy demand, available as a communication object, to activate the thermal generators and / or a circulator
- 4-channel and 4 inputs each channel logic functions, to realize combinatorial building automation logic through AND, OR, NOT and exclusive OR blocks

Other characteristics

- Housing in plastic material
- Mounting on 35 mm rail (according to EN 60715)
- Protection degree IP20 (installed device)
- Overvoltage class III (according to EN 60664-1)
- Classification climatic 3K5 and mechanical 3M2 (according to EN 50491-2)
- Pollution degree 2 (according to IEC 60664-1)
- 4 modular units (1 unit = 18 mm)
- Weight 160 g
- Dimensions 72 x 90 x 70 mm (WxHxD)

Use

The device may be used as simple actuator or as actuator / controller.

Actuator

The device receives controls and parameters via bus by one or more KNX room temperature controllers.

- 8 or 4 ON / OFF or PWM independent outputs respectively for 2-pipe or 4-pipe installations
- Heating / cooling changeover from bus

Actuator / controller

The device receives the temperature value via bus by one or more KNX temperature sensors.

- 8 independent regulators (2-pipe systems) or 4 independent regulators (4-pipe systems), ON / OFF or PWM
- Heating / cooling changeover from the bus (2 or 4-pipe systems) or automatic switching based on the room temperature (4-pipe systems)
- Management with single setpoint or absolute or relative setpoint with that may be activated through the HVAC system mode
- Acquisition of two room temperature values received via bus from other KNX devices with calculation of a weighted average
- Surface temperature limiting function through value received from the bus for heating applications with radiant panels
- Anti-condensation protection function through sensor status received from the bus for cooling applications with radiant panels
- Energy saving functions with limitations and / or extension of comfort mode, with status received via bus from window contacts or presence sensors

Technical data

Power supply

- 30 Vdc from bus (electronics)
- 230 Vac 50/60 Hz or 24 Vac (loads)
- Current consumption from bus < 30 mA
- Power consumption from bus 720 mW

TRIAC outputs

- Nr: 8 independent (2-pipe systems)
4 coupled (4-pipe systems)
- Max current I_{max} : 2(1) A
- Max 4 electrothermal actuators in parallel for each TRIAC output 0,5(0,3) A max

Environmental conditions

- Operating temperature: 0 ... + 55°C
- Storage temperature: - 25 ... + 55°C
- Transport temperature: - 25 ... + 70°C
- Relative humidity: 95% not condensing)



Note. For controlling loads different than electrothermal drives and servomotors for zone valve or loads with rated current higher than the maximum current, interface relays must be used.

Switching, display and connection elements

The device is provided with a membrane front keypad with signalling LEDs and pushbuttons, programming LED and pushbutton, a terminal for connecting the KNX bus line and screw terminals for connecting the power supply and the outputs.

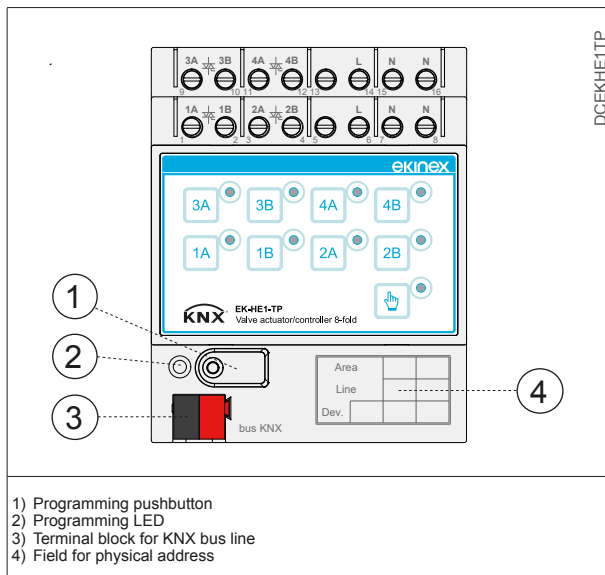

Membrane keypad

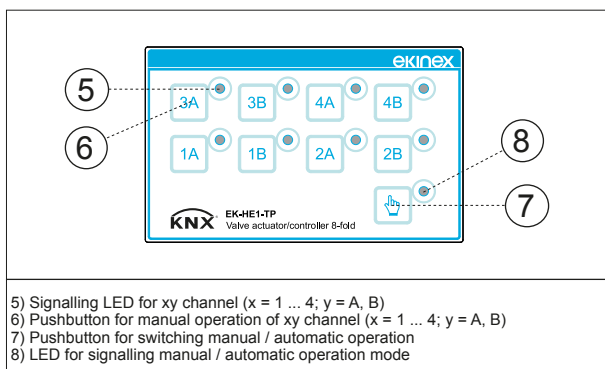

Note. To switch between manual mode and automatic mode (and vice versa), press the appropriate pushbutton for a time > 3 s.

Signalling LED

LED	Status	Meaning
Single channel	on	Presence of power supply
	off	Absence of power supply
Group of 4 channels	slow blinking (1 s)	Absence of power supply for a 4-channels group
Single channel	fast blinking (1 / 4 s)	Short-circuit alarm*
Pushbutton manual / automatic	on	Manual mode active
	off	Automatic mode active

*) To acknowledge a short-circuit alarm, keep pressed the corresponding channel pushbutton for a time > 3 s.

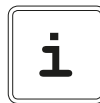

Note. Use only servomotors for zone valve equipped with stroke-end microswitches.

Terminal blocks for power supply and outputs

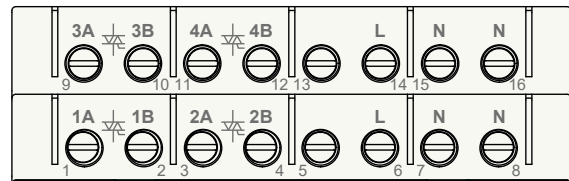

Nr.	Sign	Connection
1	1A	TRIAC output for valve drive
2	1B	TRIAC output for valve drive
3	2A	TRIAC output for valve drive
4	2B	TRIAC output for valve drive
9	3A	TRIAC output for valve drive
10	3B	TRIAC output for valve drive
11	4A	TRIAC output for valve drive
12	4B	TRIAC output for valve drive
6, 14	L	Power supply phase (230 Vac or 24 Vac)
7, 8, 15, 16	N	Power supply neutral (230 Vac or 24 Vac)

Mounting

The device has degree of protection IP20, and is therefore suitable for use in dry interior rooms. The housing is made for rail mounting according to EN 60715 in boards or cabinets for electrical distribution. The correct mounting is when the KNX bus terminal is located at the bottom. When installing be sure to leave accessible only the front panel; all other sides must not be accessible. For the installation of the device on the rail proceed as follows:

- with the aid of a tool bring the locking device in the fully lowered position (1);
- place the upper edge of the rear inner profile on the upper edge of the rail (2);

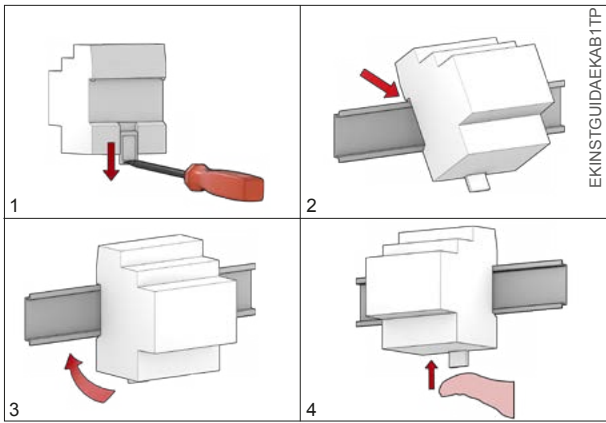

EKINSTGUIDAEKAB1TP



Note. When mounting the device in boards and cabinets it shall be provided the necessary ventilation so that the temperature can be kept within the operating range of the device.

- rotate the device towards the rail (3);
- push the locking device upward until it stops (4).

Before removing the device, be sure that power supply and controlled loads have been disconnected and the bus terminal has been extracted from its slot. Use a screwdriver to slide down the locking device and remove the device from the rail.

Connection of the KNX bus line

The connection of the KNX bus line is made with the terminal block included in delivery and inserted into the slot at the bottom of the housing.

Characteristics of the KNX terminal block

- spring clamping of conductors
- 4 seats for conductors for each polarity
- terminal suitable for KNX bus cable with single-wire conductors and diameter between 0.6 and 0.8 mm
- recommended wire stripping approx. 5 mm
- color codification: red = + (positive) bus conductor, black = - (negative) bus conductor

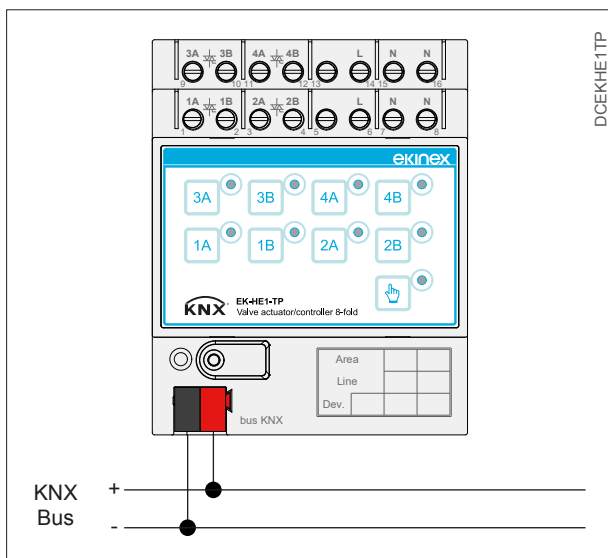

Warning! In order to supply the KNX bus lines use only KNX bus power supplies (e.g. ekinex EK-AB1-TP or EK-AG1-TP). The use of other power supplies can compromise the communication and damage the devices connected to the bus.

Connection of the power supply

The connection of the 230 Vac or 24 Vac power supply is made with the screw terminals (L, N) located at the top front of the device.

Characteristics of the terminals

- screw clamping of conductors
- maximum cross section of conductor 2,5 mm²
- recommended wire stripping approx. 6 mm
- torque max 0,5 Nm



Warning! The electrical connection of the device can be carried out only by qualified personnel. The incorrect installation may result in electric shock or fire. Before making the electrical connections, make sure the power supply has been turned off.

Connection of the outputs

The connection of the outputs is made with the screw terminals located at the top front of the device.

Characteristics of the terminals

- screw clamping of conductors
- maximum cross section of conductor 2.5 mm² (single-wire) or 1.5 mm² (multi-wire)
- recommended wire stripping approx. 6 mm
- torque max 0.8 Nm

To reduce the total starting current, in case of simultaneous activation of two or more output channels, it is preferable to enable the delayed start function during configuration via the ETS; in this case, each output channel is activated with a delay time after the previous channel. The delay is adjustable in the range 5 ... 40 s and is equal for all channels.



Warning! The number of electrothermal actuators that can be connected in parallel to each output is limited by the rated current and the starting current of the device. Carefully check the information on the technical documentation of the manufacturer of actuators.

Connection in 4-pipe systems

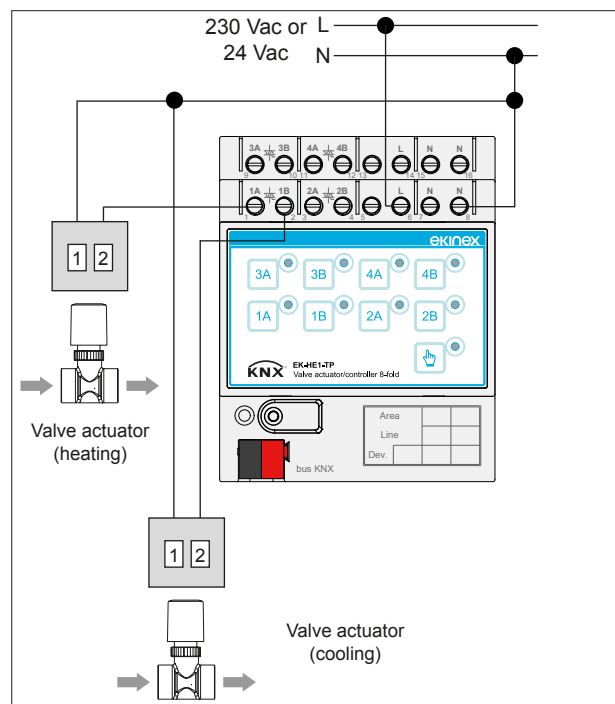



Note. When using in installations with 4-pipe hydraulic distribution, the outputs have to be used respecting the coupling between the channel pairs 1A-1B, 2A-2B, 3A-3B, 4A-4B.

Connection in 2-pipe systems

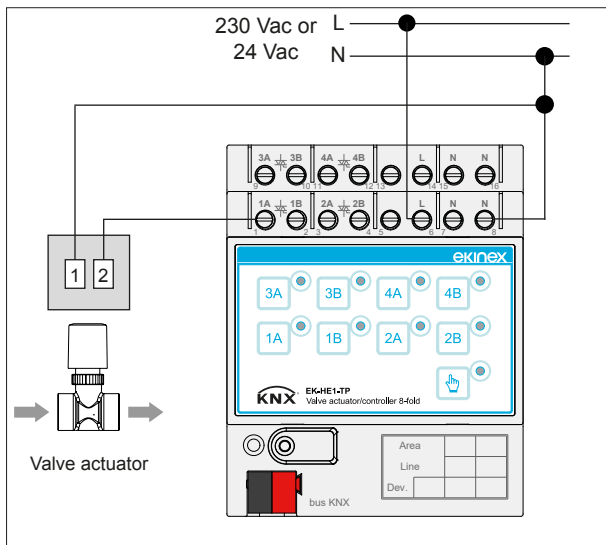

Configuration and commissioning

Configuration and commissioning of the device require the use of the ETS® (Engineering Tool Software) program V4 or later releases. These activities must be carried out according to the design of the building automation system done by a qualified planner.



Note. The configuration and commissioning of KNX devices require specialized skills. To acquire these skills, you should attend the workshops at KNX certified training centers.

Configuration

For the configuration of the device parameters the corresponding application program or the whole ekinex® product database must be loaded in the ETS program. For detailed information on configuration options, refer to the application manual of the device available on the website www.ekinex.com.

Product code	Application program (## = release)	Communication objects (nr. max)	Group addresses (nr. max)
EK-HE1-TP	APEKHE1TP##.knxprod	244	244

Commissioning

For commissioning the device the following activities are required:

- make the electrical connections as described above;
- turn on the bus power supply;
- switch the device operation to the programming mode by pressing the programming pushbutton located on the front side of the housing. In this mode of operation, the programming LED is turned on;
- download into the device the physical address and the configuration with the ETS® program.

At the end of the download the operation of the device automatically returns to normal mode; in this mode the programming LED is turned off. Now the bus device is programmed and ready for use.

Reset of the device

To reset the device remove the bus connection by extracting the bus terminal from its seat. Keeping pressed the programming pushbutton, reinsert the bus terminal in his seat; the programming LED blinks fast. Release the programming button and remove the bus terminal again; the reset was carried out. Now you need to address and configure again the device via ETS.



Warning! The reset restores the device back to the state of delivery from the factory. The address and the value of the parameters set during configuration will be lost.

Dimensions [mm]

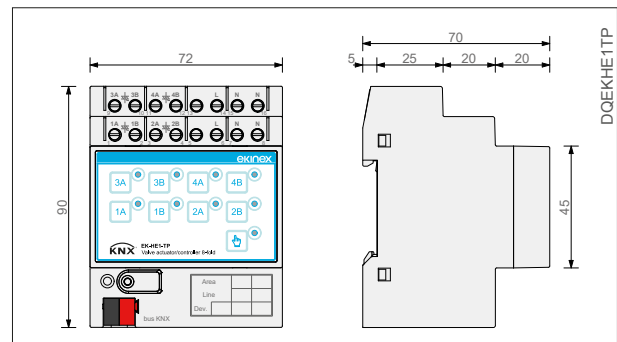

Marks

- KNX
- CE: the device complies with the Low Voltage Directive (2014/35/EC) and the Electromagnetic Compatibility Directive (2014/30/EC). Tests carried out according to EN 50491-2:2010, EN 50491-3:2009, EN 50491-4-1:2012, EN 50491-5-1:2010, EN 50491-5-2:2010, EN 50428:2005 +A1:2007 + A2:2009

Maintenance

The device is maintenance-free. To clean use a dry cloth. It must be avoided the use of solvents or other aggressive substances.

Disposal



At the end of its useful life the product described in this datasheet is classified as waste from electronic equipment and cannot be disposed together with the municipal undifferentiated solid waste.



Warning! Incorrect disposal of this product may cause serious damage to the environment and human health. Please be informed about the correct disposal procedures for waste collecting and processing provided by local authorities.

Documentation

This datasheet refers to the release A1.0 of the ekinex® device EK-HE1-TP, and is available for download at www.ekinex.com as a PDF (Portable Data Format) file.

File name	Device release	Updating
STEKHE1TP_IT.pdf	A1.0	11 / 2016

Warnings

- Installation, electrical connection, configuration and commissioning of the device can only be carried out by qualified personnel in compliance with the applicable technical standards and laws of the respective countries
- Opening the housing of the device causes the immediate end of the warranty period
- In case of tampering, the compliance with the essential requirements of the applicable directives, for which the device has been certified, is no longer guaranteed
- ekinex® KNX defective devices must be returned to the manufacturer at the following address: SBS S.p.A. Via Circonvallazione s/n, I-28010 Miasino (NO) Italy

Other information

- This datasheet is aimed at installers, system integrators and planners
- For further information on the product, please contact the ekinex® technical support at the e-mail address: support@ekinex.com or visit the website www.ekinex.com
- Each ekinex® device has a unique serial number on the label. The serial number can be used by installers or system integrators for documentation purposes and has to be added in each communication addressed to the SBS technical support in case of malfunctioning of the device
- ekinex® is a registered trademark of SBS S.p.A.
- KNX® and ETS® are registered trademarks of KNX Association cvba, Brussels

© SBS S.p.A. 2016. The company reserves the right to make changes to this documentation without notice.