

ekinex

CONTROL YOUR LIVING SPACE



Application Manual actuator/controller 8 channels for electrothermal valve drives EK-HE1-TP

Sommario

1	Scope of the document.....	5
2	Product description.....	6
2.1	General characteristics.....	6
2.2	Electrical characteristics.....	7
3	Switching, display and connection elements.....	8
4	Configuration.....	10
5	Commissioning.....	10
6	Function description.....	11
6.1	Switching on.....	11
6.2	Offline operation.....	11
6.2.1	Operation with bus power only.....	11
6.2.2	Operation with loads power supply only.....	11
6.3	Manual operation.....	12
6.3.1	Output status when mode changes.....	12
6.3.2	Manual mode activation.....	12
6.4	Online operation.....	14
6.4.1	Software working cycle.....	14
6.4.2	State variables (communication objects).....	14
6.5	Applications.....	14
6.6	Output configuration.....	15
6.6.1	Supply voltage selection.....	15
6.6.2	NO and NC outputs.....	15
6.6.3	Activation delay.....	16
6.6.4	Parallel outputs.....	16
6.7	Short-circuit and power supply fault alarm.....	16
6.8	Energy request management.....	17
6.9	Operation as actuator.....	18
6.9.1	Choosing the control variable type.....	18
6.9.2	Control variable timeout alarm.....	18
6.9.3	Initialization status reading.....	18
6.10	Operation as controller and actuator.....	19
6.10.1.1	Control algorithms.....	19
6.10.1.2	Two-point control with hysteresis.....	19
6.10.1.3	PWM Proportional-Integral control.....	21
6.10.2	Setpoint management.....	22
6.10.3	Operating modes.....	23
6.10.4	Heating/cooling switch over.....	24
6.10.5	Temperature control alarm.....	25
6.11	Inputs from bus.....	25
6.11.1	Characteristics and timeout.....	25
6.11.2	Weighted temperature.....	25
6.11.3	Surface temperature limitation function.....	26
6.11.4	Anticondensation protection function.....	26
6.11.5	Window contacts.....	27

6.11.6	Presence sensors	27
6.12	Valve protection	29
6.13	Forced mode outputs	29
7	Application program for ETS	30
7.1	About EK-HE1-TP	31
7.2	General	31
7.3	Channel configuration	34
7.4	Channel xA/B – Valve control / Channel x – Valve control heating/cooling	37
7.5	Channel x - xA/B – Temperature control	40
7.5.1	Settings	40
7.5.1.1	Monitoring and remote command of the conduction mode	42
7.5.1.2	Remote operating mode modification	43
7.5.2	External sensors (from bus)	44
7.5.3	Heating	46
7.5.3.1	Remote Setpoint modification	50
7.5.4	Cooling	51
7.5.5	Windows contacts	55
7.5.6	Presence sensors	56
7.6	Logic functions	57
8	Appendix	59
8.1	List of KNX communications objects	59
8.2	Retentive communication objects	62
8.3	Error indications	64
8.4	Application examples	65
9	Warnings	68
10	Other information	68

Revision	Modifications	Date
1.00	Emission	29/11/2016

1 Scope of the document

This application manual describes application details for the A1.0 release of the ekinex® actuator/controller EK-HE1-TP.

This document is aimed at the system configurator as a description and reference of device features and application programming. For installation, mechanical and electrical details of the device please refer to the technical description datasheet.

Application manual and application programs for ETS are available for download at www.ekinex.com.

Item	File name (## = release)	Version	Device rel.	Update
Product datasheet	STEKHE1TP##_IT.pdf	EK-HE1-TP	A1.0	11/2016
Application manual	MAEKHE1TP##_IT.pdf		A1.0	11/2016
Application program	APEKHE1TP##_knxprod		A1.0	11/2016

You can access the most up-to-date version of the full documentation for the device using following QR code:

EK-HE1-TP



2 Product description

The ekinex® EK-HE1-TP actuator/controller is a 35mm rail mounting KNX device for electrothermal actuators and/or zone valve drives installed on distribution manifolds in radiating plants. Its 8 output channels use TRIACs in order to provide a silent command and a high number of cycles both with 230 Vac and 24 Vdc power supply, and both in combination with NC (normally closed without power supply) and NO (normally open without power supply) actuators. This product can be used on both 2-pipe and 4-pipe plants: in the latter, it is possible to interlock the outputs by fully closing the active valve before its coupled valve starts to open, in order to prevent heating and cooling fluids from mixing together.

This product is equipped with a membrane keyboard for its outputs to be controlled manually, and LED indicators to diagnose the device's status and alarms related to any outputs' short-circuit or lack of power supply.

This device can work as actuator in combination with one or more room thermostats installed on the KNX network, or as actuator/controller with acquisition of max. 2 temperature values from KNX sensors.

This device is equipped with an integrated KNX communication module and is suitable for 35mm rail mounting, according to EN 60715. It is powered by the KNX bus line with a 30 VDC SELV voltage and the supply of the power side is supplied by electric power distribution (230 Vac, 50-60 Hz).

The supply includes, inside the box:

- one device;
- 1 KNX terminal block for the connection of the bus line;
- an instruction sheet.

2.1 General characteristics

General functional characteristics:

- 8 globally configurable channels to be used with NC (normally closed without power supply) or NO (normally open without power supply) actuators
- Independent configuration for each output channel as actuator, 2-pipe or 4-pipe actuator/controller, parallel channel or simple output controller by a communication object
- Detection and indication of short-circuits by monitoring of the amount of current absorbed by the electrothermal actuators connected to the outputs.
- Detection and indication of power supply fault on the electrothermal actuators connected to the outputs
- Selective enabling of a single channel for one conduction mode only. In floor radiant panel applications, it is possible to set variable steps according to the current season in order to achieve a better cooling performance
- Valve protection function during long inactivity periods.
- Delayed output activation (range: 5-40 s) in order to avoid power absorption peaks by the electrothermal actuators
- Automatic assessment for energy requests, available as a communication object, in order to activate thermal generators and/or a circulator.
- 4-channel and 4 inputs per channel logic functions for building automation combinatory logics through AND, OR, NOT and XOR function blocks.

Channels configured as actuators:

- 8 independent channels (2-pipe) or 4 coupled channels (4-pipe), with ON/OFF or PWM command
- Heating/cooling switchover from bus

Channels configured as integrated temperature controllers

- 8 independent controllers (2-pipe) or 4 independent controllers (4-pipe), with ON/OFF or PWM command
- Heating/cooling switchover from bus (2-4-pipe) and automatic switchover based on room temperature (4-pipe)
- Single set-point management, with absolute or relative set-point enabled through HVAC system mode
- Acquisition of 2 room temperature values received by bus from different KNX device, with weighted average elaboration
- Surface temperature limitation function, through a value received by bus, for heating applications involving radiant panels
- Anticondensation protection function, through a state received by bus, for cooling applications involving radiant panels
- Energy saving functions with comfort limitation and/or comfort extension, through states received by bus from window contacts or presence sensors.



The regulation with KNX devices, although properly configured and commissioned, cannot by any means make up for the undersizing or oversizing of thermal generators, distribution network and terminals.

2.2 Electrical characteristics

Product code	EK-HE1-TP
No. of outputs	8
Auxiliary power supply for actuators	24 Vac / 230 Vac
Triac outputs max current (for each outputs)	2(1) A
No. of electrothermal actuators for each channel	a 230 Vac: 4 in parallel for each channel a 24 Vac: 4 in parallel for each channel
Logic part power supply (microcontroller)	dal bus KNX
Bus current consumption	< 30 mA
Operating temperature	0°C... +45°C
Protection degree	IP20
Dimensions	72 x 90 x 60 mm (L x H x P)

3 Switching, display and connection elements

The front side of the EK-HE1-TP device is fitted with a membrane keyboard with keys and LEDs, and terminal blocks. The membrane keyboard can be deactivated by means of a proper parameter while configuring the device.

When switching the device in manual mode, by acting on the membrane keys it is possible to activate the device's outputs; this allows testing the connected valves and fan group. On the front side there is also a pushbutton for programming mode activation with relative LED and the terminals for connecting the KNX bus line.

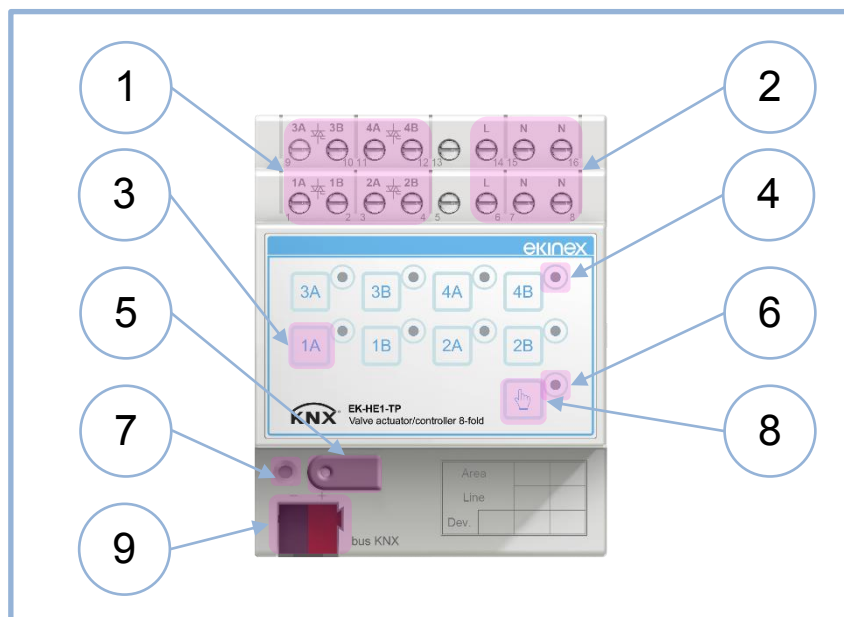

Figure 1 - Switching, display and connection elements EK-HE1-TP

<ol style="list-style-type: none"> 1. Output terminal blocks 2. Terminal block for auxiliary power supply (230 Vac/24 Vac) 3. Membrane key to manually activate outputs 4. LED indicators for outputs' status (both in manual and auto) 5. Programming pushbutton 6. LED indicator for manual mode active 7. Programming LED 	<ol style="list-style-type: none"> 8. Membrane key for manual mode activation 9. Terminal block for KNX bus line
---	--

LED indicator

LED	Status	Meaning
Single channel	On	Power supply ok
	Off	No power supply
4-channel group	Slow blinking (1 s)	No power supply on the 4-channel group
Single channel	Fast blinking (1/4 s)	Short-circuit alarm (*)
Manual/auto pushbutton	On	Manual mode active (**)
	Off	Auto mode active

(*) After the short-circuit alarm is detected, reset must be done manually. In order to silent a short-circuit alarm (after having replaced the faulty electrothermal actuator) hold the pushbutton related to the channel for more than 3 seconds.

(**) In order to switch to manual mode, hold the pushbutton for more than 3 seconds.

4 Configuration

The exact functionality of the device depends on the software settings. In order to configure and commission the device you need ETS4 or later releases and the ekinex® application program, APEKHx1TP##.knxprod, which can be downloaded from the ekinex website www.ekinex.com. The application program allows the configuration of all working parameters for the device. The device-specific application program has to be loaded into ETS or, as alternative, the whole ekinex® product database can be loaded; at this point, all the instances of the selected device type can be added to the project.

For every single device, ETS allows to set the operating parameters separately for each function as described in detail in the following chapters.

Product code	EAN	No. of channels	ETS application software (## = release)	Communication objects (max no.)	Group addresses (max no.)
EK-HE1-TP	8018417219139	-	APEKHE1TP##. knxprod	244	254



Configuration and commissioning of KNX devices require specialized skills; to acquire these skills, you should attend training courses at a training center certified by KNX.

For further information: www.knx.org.

5 Commissioning

After the device has been configured within the ETS project according to user requirements, the commissioning of the device requires the following activities:

- electrically connect the device, as described in the product datasheet, to the bus line on the final network or through a purposely setup network for programming;
- apply power to the bus;
- switch the device operation to programming mode by pressing the programming pushbutton located on the rear side of the housing. In this mode of operation, the programming LED is turned on steady;
- upload the configuration (including the physical address) to the device with the ETS program.

At the end of the upload, the operation of the device automatically returns to normal mode; in this mode the programming LED is turned off. Now the device is programmed and ready for use on the bus.

6 Function description

6.1 Switching on

After connecting the bus line, the device becomes fully functional after a short time (tenths of ms) needed for re-initialization. A delay is programmable for the device to become active on the bus in order to avoid a bus traffic overload during the first moments of start-up of the whole network.

6.2 Offline operation

The device will be partially functional in case one of the two power supplies (KNX bus line or 230 Vac/24 Vdc) should be missing. The internal circuit dedicated to logic and communication is powered by KNX bus line; output TRIACs, for consumption reasons, are powered by auxiliary supply only.

Should both power supply be off, the device will be completely not functional.

6.2.1 Operation with bus power only

In case of no power for electrothermal actuators and/or zone valve drives, all functions not related to output status are active; however, when TRIACs are switched open, loads remain without power.

In order to detect this undesired situation, a power supply fault alarm is always active; moreover, it is possible to enable 2 communication objects (alarm on outputs 1A, 1B, 2A and 2B, and alarm on outputs 3A, 3B, 4A and 4B) which activate the alarm status, so that other devices on the bus can take all proper countermeasures and/or display the anomaly to the user.

In order to show a visual indication of auxiliary power failure, all LEDs on the panel will slowly blink (1 second) in groups of 4.

6.2.2 Operation with loads power supply only

When KNX bus is disconnected, or in case of bus voltage failure (voltage less than 19 V for more than 1 s), all device functions are stopped and all output TRIACs are closed.

When power is restored, the device will resume operation in its previous state.

6.3 Manual operation

Manual operation constitutes an alternative to input switching through bus commands; this mode is meant for test or maintenance only.

6.3.1 Output status when mode changes

When manual mode is activated, outputs' statuses are not modified. When manual mode is active, the frames coming from the bus do not affect the physical outputs; the output contacts can be switched only if the corresponding membrane key on the front side is pressed.

The manual activation/deactivation of the outputs does not generate any feedback frame. The LED linked to the outputs, however, will continue to display their status nonetheless.

From another point of view, the situation could be explained by saying that during manual mode it is like the variables were temporarily "unconnected" from group addresses. When "reconnecting" them (exit from manual mode) their value remains unaltered until a new command from bus does not alter them.

The same considerations made for the command from bus are valid for state changes caused by internal timing functions (e.g. activation delays or stairs light function): those state changes have no effect while manual mode is active.

6.3.2 Manual mode activation

The actuator/controller EK-HE1-TP is fitted with a membrane keyboard to perform manual commands which are useful during commissioning phase.

In order to switch to manual mode you have to proceed as follows:

- 1) press the manual mode pushbutton on the front side of the device. During normal operation, this LED is off; when this LED goes on, the membrane keys become active and manual mode is activated;

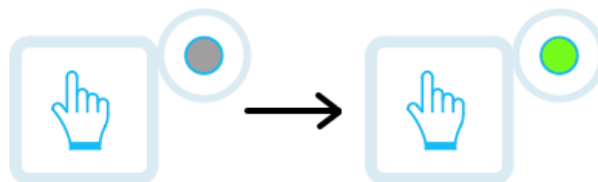

- 2) press the key corresponding to the channel you wish to activate (in the example: DO1). Pressing it several times perform a toggle between On and Off states;

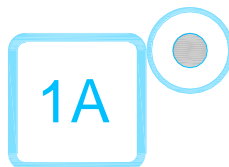

- 3) when testing phase is over, deactivate manual mode by pressing again the manual mode pushbutton. Returning to normal mode, the indicator LED will display the output state again, which will be restored as described.



The switch to manual mode through frontal panel can be inhibited in two ways, both configurable:

- by completely disabling manual mode functionality;
- by a command from bus.

Please note that the command from bus prevent the device from changing mode through the proper pushbutton, but does not actually changes the mode.

If manual mode is not inhibited from configuration nor defined as bus controlled, through a different parameter it is possible to set a timeout after that, if the device has been left in manual mode, it is automatically brought back to normal operation. This prevents the device from being left in an uncontrollable state by mistake.

6.4 Online operation

All functions described below presume that the device has been correctly configured with ETS. An unprogrammed device does not perform any task on the bus; however, it can be activated through the membrane keyboard, making it switch to manual mode.

6.4.1 Software working cycle

The tasks performed by the software are the following:

- update the internal state variables based on KNX frames;
- implement the functions related to timing and other integrated functions to determine the state of the outputs;
- activate the output TRIACs based on the logical outputs' status;
- answer to the requests related to the communication objects received via bus

In addition, there are particular events that can trigger additional features. These events are, for example, a bus power failure or restore, or an ETS new configuration load.

6.4.2 State variables (communication objects)

The device status, with particular attention to its interface elements (outputs) is based on *state variables* which are automatically defined by the application program. When a state variable is assigned to a group address, this variable automatically becomes a KNX communication object; therefore, it inherits all the usual characteristics of communication objects, such as the use of *flags* to determine the impact of the object modification on its bus transmission.

6.5 Applications

Configurable applications are specific for single-stage thermal plants and include the following devices: radiators, electric heaters, radiant floor and ceiling panel systems.

The temperature control can be:

- 2-point hysteresis, ON-OFF command;
- Proportional-integral, with ON-OFF or PWM command.

The outputs which are not used for the application can be used for purposes other than temperature control and are controlled by means of proper communication objects exposed in the application program.

6.6 Output configuration

The EK-HE1-TP device is equipped with 8 TRIAC outputs, logically grouped in pairs in order to create 4 channels (1A and 1B, 2A and 2B, 3A and 3B, 4A and 4B).

By configuring the device as heating only, cooling only or both heating and cooling (2 independent channels), each output can perform one of the following tasks:

- disabled
- external controller (actuator)
- internal controller (internal temperature controller)
- parallel
- output command

By configuring the device on both heating and cooling (2 channels paired to a 4-pipe system) each output can instead perform one of the following tasks:

- disabled
- external controller (actuator)
- internal controller (internal temperature controller)

In this case, the output xA always acts as command for the heating valve while the output xB always acts as command for the cooling valve.

6.6.1 Supply voltage selection

The EK-HE1-TP device can control electrothermal actuators and/or zone valves drives, both with 230 Vac and 24 Vac power supply. The power is supplied by a proper auxiliary terminal block (see the wiring diagram on the Datasheet) and is independent from the logic side, whose power is supplied through the KNX terminal block.



Electrothermal actuators and/or zone valves drives must be wisely selected with the same power supply (230 Vac or 24 Vac) at EK-HE1-TP terminal block in order to avoid malfunctions and/or damage to things or people.

In order to properly operate the device, supply voltage must be properly configured in ETS application program to be consistent with the actual voltage delivered to the terminals (see *Short-circuit and power supply fault alarm* paragraph for details).

6.6.2 NO and NC outputs

The EK-HE1-TP device can be used both with NC (normally closed) and NO (normally open) electrothermal actuators.

With NC electrothermal actuators, if the output is on, the corresponding valve open and water flows into the hydraulic circuit. On the contrary, with NO actuators, the TRIAC output must not be on in order to open the valve and make water flow into the circuit.

This device allows to configure the type of actuator with a selection in the application program; this selection is common to all 8 outputs.



The LED statuses on the membrane keyboard which correspond to the output have a purely electric (not hydraulic) meaning:

- LED ON: output on (NC actuators open, valves open and water flows; NO actuators close, valves close and water stops flowing).
- LED ON: output off (NO actuators open, valves open and water flows; NC actuators close, valves close and water stops flowing).

6.6.3 Activation delay

It is possible to power the outputs with some configurable delay (in the range of 5-40 s) in order to minimize the current consumption peaks that may happen when actuators are started. This delay allows to avoid the circuit breakers from tripping in the following situations:

- Failure and subsequent restore of the bus power supply when all TRIAC outputs are demanding to open (with NC actuators) or close (with NO actuators) the valves;
- Recall of comfort (with NC actuators) or building protection (with NO actuators) operating mode on all zones.

6.6.4 Parallel outputs

In all those situations where a zone is made of multiple circuits on the manifold, it is suggested to distribute the command on different EK-HE1-TP outputs, thus avoiding the execution of an electrical parallel of more than one electrothermal actuator on a single output. This configuration is possible thanks to the *parallel* function, which can be assigned to outputs with 2 independent channels. An output can be configured in parallel only to another output whose channel number is less than its own (except for output 1A that cannot be configured in parallel with any output).

Outputs can be configured in parallel only during a selected conduction mode. This function is useful, for example, in floor radiant plants, where coils are built according to different steps depending on the current season, in order to achieve a better cooling performance. For example, during heating the only controllable output is 1A, while during cooling outputs 1A, 1B and 2A can be controlled in parallel.

6.7 Short-circuit and power supply fault alarm

A short-circuit on an electrothermal actuator can happen after long inactivity periods and is usually caused by the deterioration of the thermoresistive element, whose heating determines the liquid or wax bulb to expand. The device's TRIAC outputs, overloaded with a short-circuit current, can be damaged, besides being unable to provide the environment with the proper comfort level.

A power supply fault can be caused by a wrong electrical wiring or a forced interruption (due to overloads) of a plant's section.

The EK-HE1-TP device can be configured to monitor the amount of current absorbed by its outputs as well as the power supply voltage level. In case of malfunction, an indication of failure is shown on the faceplate LEDs; moreover, there are proper communication objects which can communicate the fault to a supervision system through the bus.

The short-circuit alarm stops only the affected TRIAC output and stops the internal controller (if configured). The alarm is reported by a fast blinking (1/4 s) of the faceplate LED corresponding to the affected output. Reset is manual only, through a long press (>3 s) of the pushbutton corresponding to the affected output: if the faulty electrothermal actuator is not replaced, the output will show the alarm again.

The device foresees a unique communication object for all outputs, reporting the fault status to the supervision system.

There are 2 power supply fault alarms: the first is related to outputs 1A, 1B, 2A and 2B, the second to outputs 3A, 3B, 4A and 4B. Those alarms are always enabled (while the short-circuit alarm can be disabled through ETS application program) and it is reported by a slow blinking (1 s) of the faceplate LEDs corresponding to the affected outputs.

The device foresees 2 communication objects (grouped by 4) to report the alarms to the supervision system. These objects are enabled through ETS application program only if actuators are supplied with 230 Vac.



In order for the power supply fault alarm to activate correctly, supply voltage must be properly configured in the ETS application program to be consistent with the actual voltage delivered to the terminals and compatible with the used electrical actuators and/or servo motors (see *Short-circuit and power supply fault alarm* paragraph for details).

A wrong supply voltage configuration in the ETS application program can lead to a continuous alarm condition and a faulty behavior of the EK-HE1-TP product.

6.8 Energy request management

The EK-HE1-TP device, when operating with auxiliary controllers, internal controllers and mixed configuration, features 2 communication objects, which can be enabled in the *Channel configuration* tab, whose function is to perform a logic OR among the flow requests on the different outputs. Those 2 objects are:

- Energy request (heating)
- Energy request (cooling)

The logic OR among the flow requests is useful to activate a circulator feeding the distribution manifold and/or a thermal generator (condensating boiler or heat pump). The energy request can be triggered with a configurable delay, for example to allow the electrothermal actuators to fully open their circuits, and can be sent on the bus both cyclically and during initialization of the device.

Energy request management allows to individually enable or disable the logic OR elaboration on each output. This allows to use some outputs for functions which are independent from the distribution manifold control.

6.9 Operation as actuator

6.9.1 Choosing the control variable type

When operating as actuator, in order to make the integration with the temperature controller device easier, it is possible to use 2 Data Point Types for control communication objects.

- [DPT 1.001] switch – In 2-pipe distribution plants, the communication object for command is linked to the object *Valve on/off command – channel xA/B* through its group address. In 4-pipe distribution plants, 2 communication objects for command must be linked respectively to the objects *Valve on/off heating command – channel xA* and *Valve on/off cooling command – channel xB*.
- [DPT 5.010] percentage – In 2-pipe distribution plants, the communication object for command is linked to the object *Valve continuous command – channel xA/B*. In 4-pipe distribution plants, 2 communication objects for command must be linked respectively to the objects *Valve continuous heating command – channel xA* and *Valve continuous cooling command – channel xB*. Timing for PWM, cycle time, control max and min values are directly evaluated by the device.

It is also possible to configure the communication object format in a separate way for heating and cooling.

6.9.2 Control variable timeout alarm

In order to guarantee the reliability of the frame exchange between controller and actuator on the bus, it is possible to add a time check when every command is received: when the preset time expires, if no new commands are received, the actuator's outputs can be forced in predefined positions. The timeout value is unique for all 8 channels.



When setting a timeout different from 0, make sure to set cyclic sending of commands on the device acting as temperature controller. In order to work correctly, the cyclic sending must assume values less than the preset timeout.

6.9.3 Initialization status reading

The EK-HE1-TP device, when operating as actuator, can sync the statuses of the commands sent on the bus directly after initialization. Each output can be individually configured to read that status when the device is initialized.

6.10 Operation as controller and actuator

The room air temperature control is performed thanks to the intercept valve(s) on the heat exchange coil(s), with an ON/OFF or PWM control algorithm. In order to control those valves, electrothermal actuators and/or servomotors can be used.

6.10.1.1 Control algorithms

The picture below shows the components of a common generic control system for ambient temperature. The room thermostat measures the actual temperature of the air mass (T_{eff}) and constantly compares it to the setpoint value (T_{set}).

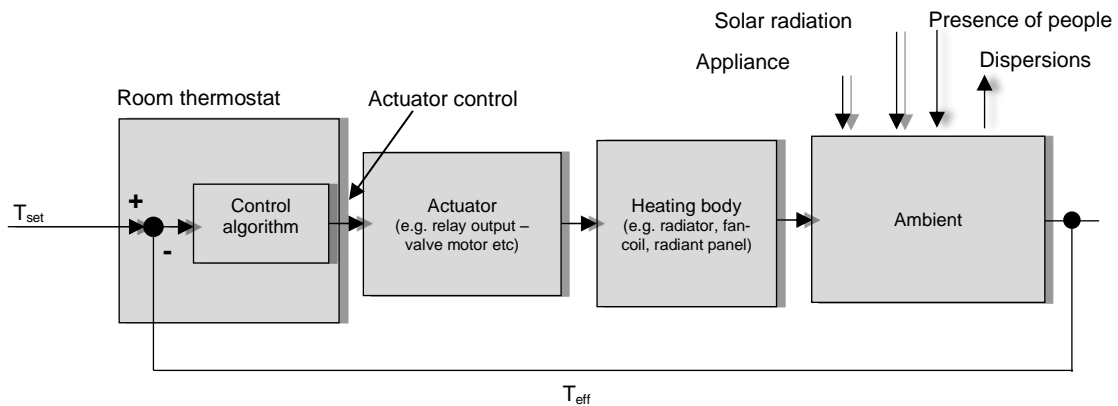

The control algorithm, basing on the difference between T_{set} and T_{eff} , processes a command value which can be of analogue or On / Off type; the command is represented by a CO that is transmitted via bus, periodically or event based, to a actuator device. The output of the actuator device is the driving variable of the control system, which can be e.g. a flow rate of water or air. The control system realized by the room thermostat is of feedback type, namely the algorithm takes into account the effects on the system in order to change the control action on the same entity.

6.10.1.2 Two-point control with hysteresis

This control algorithm, which is also known as On / Off, is the most classic and popular. The control provides for the on / off switching of the system following a hysteresis loop, i.e. two threshold levels are considered for the switching instead of a single one.

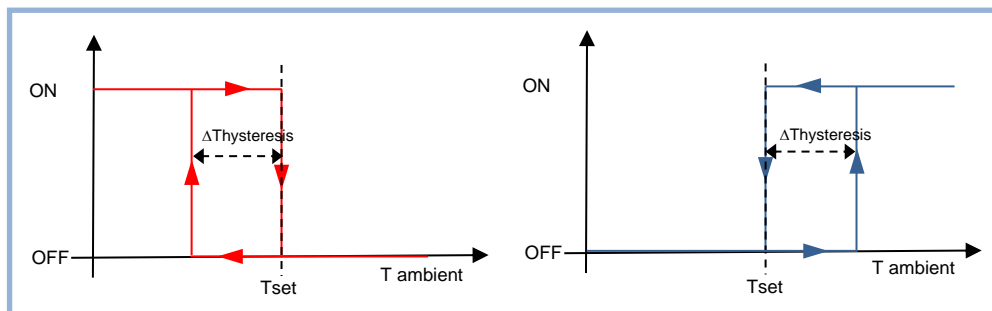

Heating mode: when the measured temperature is lower than the value of the difference ($T_{set} - \Delta T_{hysteresis}$), whereby $\Delta T_{hysteresis}$ identifies the differential adjustment of the boilers, the device activates the heating system

by sending a message or KNX telegram to the actuator that handles the heating system; when the measured temperature reaches the desired temperature (Setpoint), the device disables the heating system by sending another message. In this way, there are two decision thresholds for activation and deactivation of the heating, the first being the level ($T_{set} - \Delta T_{hysteresis}$) below which the device activates the system, whereas the second is the desired temperature above which the heating system is deactivated.

Cooling mode: When the measured temperature is higher than the value of the difference ($T_{set} + \Delta T_{hysteresis}$), whereby $\Delta T_{hysteresis}$ identifies the differential adjustment of the cooler, the device activates the air conditioning system by sending a message or KNX telegram to the actuator that handles it; when the measured temperature falls below the desired temperature T_{set} the device turns off the air conditioning system by sending another message. In this way, there are two decision thresholds for activation and deactivation of the cooling: the first being the level ($T_{set} + \Delta T_{hysteresis}$) above which the device activates the system, whereas the second is the desired temperature below which the air conditioning system is deactivated. In the ETS application program, two different parameters are available for the hysteresis value for heating and cooling: the values usually differ depending on the system type and its inertia.

In those applications where floor or ceiling radiant panels are present, it is possible to realize a different 2-point room temperature control. This type of control must be paired either to a proper regulation system for flow temperature that takes into account all internal conditions or an optimizer that exploits the thermal capacity of the building to adjust the energy contributions. In this type of control the hysteresis ($\Delta T_{hysteresis}$) of the room temperature high limit ($T_{set} + \Delta T_{hysteresis}$) represent the maximum level of deviation that the user is willing to accept during plant conduction.

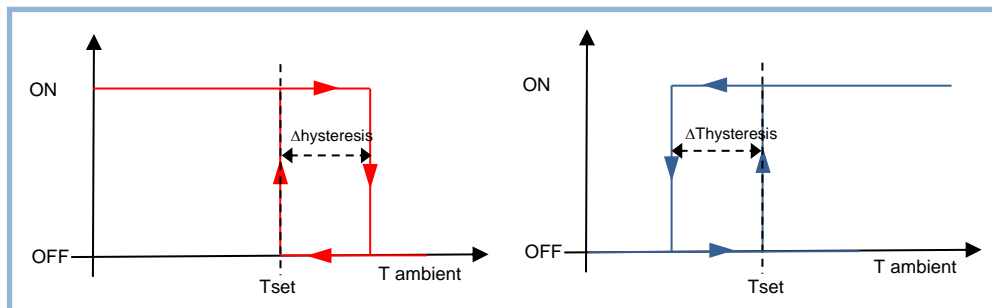

Heating mode – When the measured temperature is lower than the desired temperature T_{set} , the device activates the heating system by sending a message or KNX telegram to the actuator that handles it; when the measured temperature reaches the value ($T_{set} + \Delta T_{hysteresis}$), whereby $\Delta T_{hysteresis}$ identifies the differential adjustment of the boilers the device disables the heating system by sending another message. In this way, there are two decision thresholds for activation and deactivation of the heating, the first being the desired temperature T_{set} below which the device activates the system, whereas the second is the value ($T_{set} + \Delta T_{hysteresis}$), above which the heating system is deactivated.

Cooling mode – When the measured temperature is higher than the desired temperature T_{set} , the device activates the air conditioning system by sending a message or KNX telegram to the actuator that handles it; when the measured temperature reaches the value ($T_{set} - \Delta T_{hysteresis}$), whereby $\Delta T_{hysteresis}$ identifies the differential adjustment of the air conditioning system, the device disables the air conditioning system by sending another message. In this way, there are two decision thresholds for activation and deactivation of the air conditioning system: the first being the desired temperature T_{set} above which the device activates the system, whereas the second is the value ($T_{set} - \Delta T_{hysteresis}$) below which the air conditioning system is deactivated.

In the ETS application program, two different parameters are available for the hysteresis value for heating and cooling: the values usually differ depending on the system type and its inertia.

In the ETS application program, the default 2-point hysteresis control algorithm foresees inferior hysteresis for heating and superior for cooling. If Heating and/or cooling type = floor radiant panels or ceiling radiant panels, it is possible to select the hysteresis position according to the described second mode, i.e. with superior hysteresis for heating and inferior for cooling.

The desired temperature (T_{set}) is generally different for each one of the 4 operating modes and for heating/cooling modes. The different values are defined for the first time during ETS configuration and can be modified later on. In order to optimize energy saving (for each extra degree of room temperature, outbound dispersions and energy consumption go up 6%), it is possible to take advantage of the multifunctionality of the domotic system, for example with:

- Hour programming with automatic commutation of the operating mode by means of KNX supervisor;
- Automatic commutation of the operating mode according to window opening for air refreshment;
- Circuit deactivation when desired temperature is reached;
- Flow temperature reduction in case of partial load.

6.10.1.3 PWM Proportional-Integral control

The proportional-integral PWM (Pulse Width Modulator) controller uses an analogue control variable to modulate the duration of the time intervals in which a binary output is in the On or Off state. The controller operates in a periodic manner over a cycle, and in each period it maintains the output to the On value for a time proportional to the value of the control variable. As shown in the figure, by varying the ratio between the ON time and the OFF time, the average time of activation of the output varies, and consequently the average intake of heating or cooling power supplied to the environment.

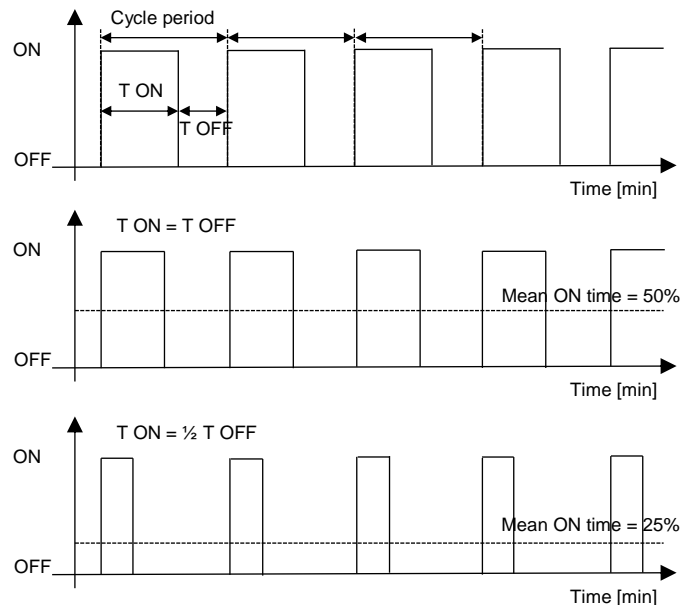

This type of controller is well suited for use with On / Off type actuators, such as relays and actuators for zone valves, which are less expensive (both for electrical and mechanical components) than proportional actuators. A distinctive advantage of this type of controller, compared with the raw On / Off controller already described, is that it eliminates the inertia characteristics of the system: it allows significant energy savings, because you avoid unnecessary interventions on the system introduced by the 2-point control with hysteresis and it only provides the power required to compensate for losses in the building.

Every time the user or the supervisor changes the desired temperature setpoint, the cycle time is interrupted, the control output is reprocessed and the PWM restarts with a new cycle: this allows the system to reach its steady state more quickly.

Terminal type	Proportional Band [K]	Integral Time [min]	Cycle Period [min]
Radiators	5	150	15-20
Electrical heaters	4	100	15-20
Fan-coil	4	90	15-20
Floor radiant panels	5	240	15-20

Guidelines for choosing the proper parameters of a PMW Proportional-Integral controller:



- Cycle time: for low-inertial systems such as heating and air conditioning systems, short cycle times must be chosen (10-15 minutes) to avoid oscillations of the room temperature.
- Narrow proportional band: wide and continuous oscillations of the room temperature, short setpoint settling time.
- Wide proportional band: small or no oscillations of the room temperature, long setpoint settling time.
- Short integral time: short setpoint settling time, continuous oscillations of the room temperature.
- Long integral time: long setpoint settling time, no oscillations of the room temperature.

6.10.2 Setpoint management

The device is not equipped with a local interface to control the integrated room thermostat, therefore the temperature setpoint modifications need to be performed by another KNX device (supervisor) and sent to this device through communication objects.

Three setpoint management modes are foreseen:

- Single setpoint;
- Relative setpoints;
- Absolute setpoints.

Single setpoint mode

In this mode, a unique communication object is exposed (*Input Setpoint*) to modify the desired temperature. This object can be updated cyclically or on event of change by the supervisory device. If power goes down, the last value is retained into the pushbutton's non-volatile memory. In case the object is not updated, the temperature controller acts anyway on default setpoints (both heating and cooling) set in the application program during commissioning.



If a temperature controller is set on both heating and cooling mode, it is necessary that the supervisory device also updates the input seasonal mode object (*Heating/cooling status in*, [1.100] DPT_Heat_Cool) in order to coherently switch over the controller's action.

If window contacts for energy saving are used, when detecting an open window the input setpoint freezes and the pre-set building protection setpoint is activated (the relative communication object is exposed and is different in heating or cooling mode).

Relative setpoints mode

In this mode, 4 communication objects are exposed, one for each operating mode:

- Comfort setpoint
- Stand-by offset
- Economy offset
- Building protection setpoint

Stand-by and economy setpoints are represented as attenuations to the comfort setpoint in order to facilitate the supervisor management: by uniquely modifying the comfort setpoint, references for attenuated modes are automatically transferred. The values modified from bus are retained in the pushbutton's non-volatile memory.

With this mode, the supervisory device can develop an hour-based time scheduling by sending to the device the current operating mode (comm. obj. *HVAC mode in* [20.102] DPT_HVAC Mode). The default value for *HVAC mode in* corresponds to the comfort setpoint value.

Same as single setpoint management, if the temperature controller is set as both heating and cooling mode with switch over from bus, it is necessary that the supervisory device also updates the input seasonal mode object (*Heating/cooling status in*, [1.100] DPT_Heat_Cool) in order to coherently switch over the controller's action.

Absolute Setpoint mode

In this mode, 3 communication objects are exposed, for each conduction mode:

- Comfort setpoint;
- Standby setpoint;
- Economy setpoint;
- Building protection setpoint.

All setpoint are absolute values: by modifying those values from bus through communication objects you need to keep the coherence among the values of the attenuated operating modes.

With this mode, the supervisory device can develop an hour-based time scheduling by sending to the device the current operating mode (comm. obj. *HVAC mode in* [20.102] DPT_HVAC Mode). The default value for *HVAC mode in* corresponds to the comfort setpoint value.

Same as single setpoint management, if the temperature controller is set as both heating and cooling mode with switch over from bus, it is necessary that the supervisory device also updates the input seasonal mode object (*Heating/cooling status in*, [1.100] DPT_Heat_Cool) in order to coherently switch over the controller's action.

6.10.3 Operating modes

In Single Setpoint mode, 2 levels for each conduction mode are available:

- Temperature setpoint
- Building protection setpoint

Time scheduling for attenuation can be realized by the supervisor, by directly modifying the temperature setpoint.

In Relative and Absolute Setpoint mode, 4 different operating modes are available, which are mutually exclusive to one another:

- comfort;
- stand-by;

- economy;
- building protection.

Through ETS application program, it is possible to assign 2 different setpoint values to each operating mode, for comfort and building protection level, and two different attenuation levels for stand-by and economy, corresponding to both heating and cooling.

Each setpoint is exposed through communication objects. Setpoints and attenuations can be modified remotely through the exposed communication objects. The setpoint intervention for building protection must be planned in ETS application program, as these parameters concern the safety and protection of the plant's components (especially during heating).

6.10.4 Heating/cooling switch over

The switch over between both heating and cooling mode can take place in 3 ways:

1. from KNX bus, through a communication object;
2. automatically, based on the room temperature.

Switchover from bus

In mode 1, the switch over command is issued through KNX bus and therefore it is performed by a different KNX device, e.g. the ekinex® Touch&See unit. The integrated temperature controller acts as a "slave": the switch over is carried out by input communication object [DPT 1.100 heat/cool].

Automatical switch over, based on the room temperature

Mode 2 is suitable for applications with heating / cooling systems with a 4-pipe configuration and is available in EK-HC1-TP version only. In addition, the information can be transmitted on the bus through an output communication object [DPT 1.100 heat/cool]; the difference with mode 1 is that the switch over is performed automatically by the machine, basing on the values of current temperature and setpoint. The automatic switch over is achieved by introducing a dead band as shown in the following figure.

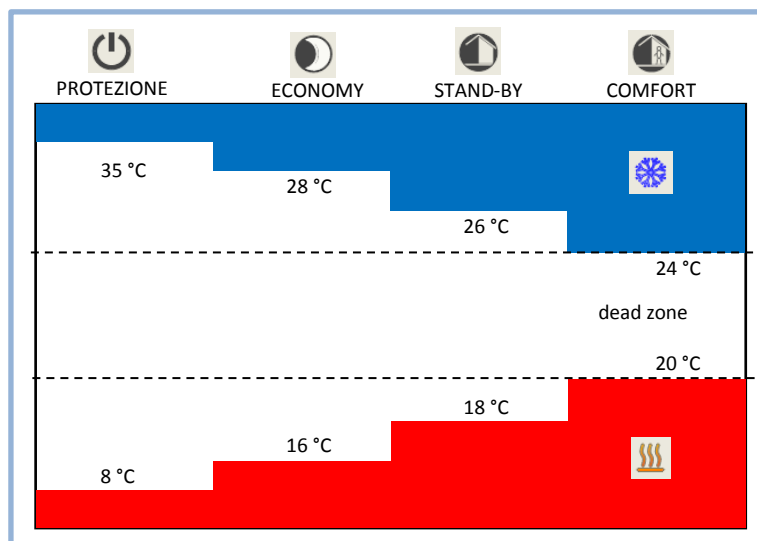

The figure shows that, as long as the actual measured temperature is below the heating mode setpoint, the heating mode is selected; similarly, if the value is greater than the cooling setpoint, then cooling mode is selected. If the value is within the dead band, the operation mode remains unchanged; the heating/cooling switchover point must correspond to the actual setpoint of the current HVAC mode, and in the same way the cooling/heating switchover must correspond to the actual heating setpoint.

An automatic switchover can be performed by interlocking the valves based on the time needed by the actuator to make a complete run. The switchover sequence includes the full closing of all intercept valves of, for example, the hot fluid, before starting to open the valves of the cool fluid. This sequence can be realized with both electrothermal actuators and zone valve drives.

Note about using valve drives



The EK-HE1-TP device can control zone valve drives with both external controller (as actuator) and internal controller.

It is mandatory to use drives equipped with mechanic or electromechanic limit switches. A TRIAC output stays in conduction mode until the desired room temperature conditions are met or when the bus commands it to open. Drives shutting down the TRIAC output by calculating the valve's opening time are not supported, besides the interlocked switchover function.

6.10.5 Temperature control alarm

The integrated temperature controller can stop the internal control algorithm for one of the following reasons:

- For an external event, which can be configured and linked to the *Thermal generator lock* communication object;
- For an internal temperature sensor's fault (measured room temperature too low while NTC resistance value is too high or vice versa);
- For a timeout (data not updated by the bus) when a weighted mean between the internal sensor's value and an auxiliary external sensor's value is used.

When one of these events occur, the internal controller stops the control algorithm and the command output is taken to complete closing position (OFF or 0%): this state is indicated through the communication object *Temperature control alarm*.

6.11 Inputs from bus

6.11.1 Characteristics and timeout

When using the device with integrated temperature controllers, variables acquired from the bus are available, which are different for each channel. All bus inputs allow to extend the device's functionality.

6.11.2 Weighted temperature

The device allows the acquisition of the room temperature in 2 ways:

- 1) from an external temperature sensor connected to a device input configured as analogic (Inputs \Rightarrow Input 1 or 2 = [AI] room temperature sensor);

- 2) via bus from another KNX device, e.g. from an ekinex pushbutton (External sensors (from bus) ⇒ Room temperature = enabled);

To optimize or correct the room temperature regulation in special cases (in large rooms, in presence of strong asymmetry of the temperature distribution, when the installation of the device is in a position not suitable, etc.), the device can then use a weighted average between two temperature values. The weights are assigned by the parameter *Relative weight* that assigns a ratio of the two values.

6.11.3 Surface temperature limitation function

The floor heating system (warm water version) provides plastic pipes embedded in the concrete layer or placed directly under the final coating of the floor (light or "dry" system) filled by heated water. The water releases heat to the final coating that heats the room by radiation. The standard EN 1264 Floor heating (Part 3: Systems and components - Dimensioning) prescribes a maximum allowed temperature (T_{Smax}) for the surface of the floor that is physiologically correct defined as:

- $T_{Smax} \leq 29^{\circ}\text{C}$ for zones of normal occupancy;
- $T_{Smax} \leq 35^{\circ}\text{C}$ for peripheral zones of the rooms.

National standards may also limit these temperatures at lower values. Peripheral zones are strips generally located along the external walls with a maximum width of 1 m.

The floor heating system (electrically powered version) involves the laying under the floor coating of an electric cable powered by the mains voltage (230 V) or low voltage (for example 12 or 45 V), possibly already prepared in the form of rolls with constant distance between sections of cable. The powered cable releases heat to the overlying coating that heats the room by radiation. The regulation is based on measurement of the temperature of the air mass, but generally requires the monitoring and limiting of the surface temperature by using a NTC-type sensor which is in contact with the floor surface.

The surface temperature limitation may be realized for several purposes:

- physiological compatibility (correct temperature at the height of the legs);
- when the system is used as auxiliary stage for heating. In this case, the heat losses to the exterior of the building are handled by the main heating stage, while the auxiliary stage only works to keep the floor temperature at a comfortable level (for example in bathrooms of residential buildings, sports centers, spas and thermal baths, etc.);
- protection against damages of the final coating due to an accidental overheating. Note that the warm water radiant panels are usually already equipped with a safety thermostat (with intervention on the hydraulic mixing group), while in the case of electrical power this device is not usable and it is common practice to realize a temperature limitation with a surface temperature sensor connected to the device.

The surface temperature limitation function closes the intercept valves on the distribution manifold when the temperature measured on the panel rises above set threshold (default value 29°C). The regular operation of the room thermostat resumes when the measured surface temperature drops below the hysteresis threshold ($29^{\circ}\text{C} - 0,3 \text{ K}$). For related alarms please refer to the Appendix.

6.11.4 Anticondensation protection function

The objective of this function is to prevent the condensation on the thermal exchange surfaces of the installation or building when cooling is working. This function is mainly used in systems with thermal exchange consisting in surface terminals such as for the floor and ceiling cooling radiant systems. In this case the hydraulic circuits contain refrigerated water; usually the latent loads (due to the increase of air humidity in the room) are handled by air-conditioning units and the temperature and humidity conditions are far from those that could cause condensation. If this is not done in a satisfactory manner, or in case of stop of the air-

conditioning units, it is necessary to provide additional safety measures to prevent or restrict the accidental formation of condensation on cold surfaces.

The alarm contact must be connected to an input channel of another KNX device, for example a pushbutton interface or a binary input. In this case the signal coming from the probe is sent to the channel of the EK-HE1-TP via bus through a communication object.

In case of anticondensation alarm, if the temperature controller is in cooling mode and is demanding for fluid, the intercept valve is closed. Its resume to normal is automatic as soon as the sensor returns to normal operation. For related alarms please refer to the Appendix.

6.11.5 Window contacts

In order to realize energy-saving functions, window contacts (to detect the opening of windows or doors) can be used. The device can acquire the status of a contact by means of a digital input or receive the status of two contacts connected to different KNX devices (binary inputs, pushbutton interfaces). When a window opens, the device automatically switches to *Building Protection* operating mode; when it closes, the device automatically returns to the previous operating mode. When acquiring two signals, they can be combined in logical OR.

The window contact management is an optional feature, oriented to energy saving, which is available only when the actuator/controller EK-HE1-TP is configured as integrated temperature controller. When an open window is detected, the operating mode is forced into building protection and remains forced until all windows are closed. The application program features a time parameter for opening delay to discriminate between an occasional, short opening and a long opening, which justifies the energy saving mode recall.

The window contact management has absolute priority over the operating mode forced by time scheduling, over the mode forced by presence sensors (if enabled) and over the HVAC mode forced by supervisor through the communication object *HVAC Forced mode in DPT 20.102*.

6.11.6 Presence sensors

Presence sensors management includes a set of optional features, oriented to energy saving, which become available when the device is configured as integrated controller.

Generally speaking, if a human presence is detected and limited to the occupancy period, the comfort operating mode can be extended; vice versa, if no presence is detected, the comfort operating mode can be limited, because no longer necessary.

The occupancy status detection is performed by presence sensors which can be connected to KNX devices equipped with binary inputs; the actuator/controller EK-HE1-TP exposes 1 1-bit communication objects for each one of the 8 channels; these objects are then synchronized to the situations detected by the sensors.

In order to determine which physical state corresponds to the presence state, two different options can be selected:

- Not inverted (normally closed): an open contact corresponds to non-occupancy state, a close contact corresponds to detected presence;
- Inverted (normally open): an open contact corresponds to detected presence, a close contact corresponds to non-occupancy state;

There are three presence state management modes: comfort extension, comfort limitation and a combination of these two modes.

Comfort extension. This function is only active if the actual operating mode is set on comfort; if, during this time, a presence is detected, the operating mode remains comfort even if the operating mode forced by the

time scheduling function shifts to economy or standby. If a presence is not detected for a time period less than a preset time, the operating mode does not change; vice versa, if a presence is not detected for a time period greater than the same preset time, the operating mode becomes the one forced by the time scheduling function.

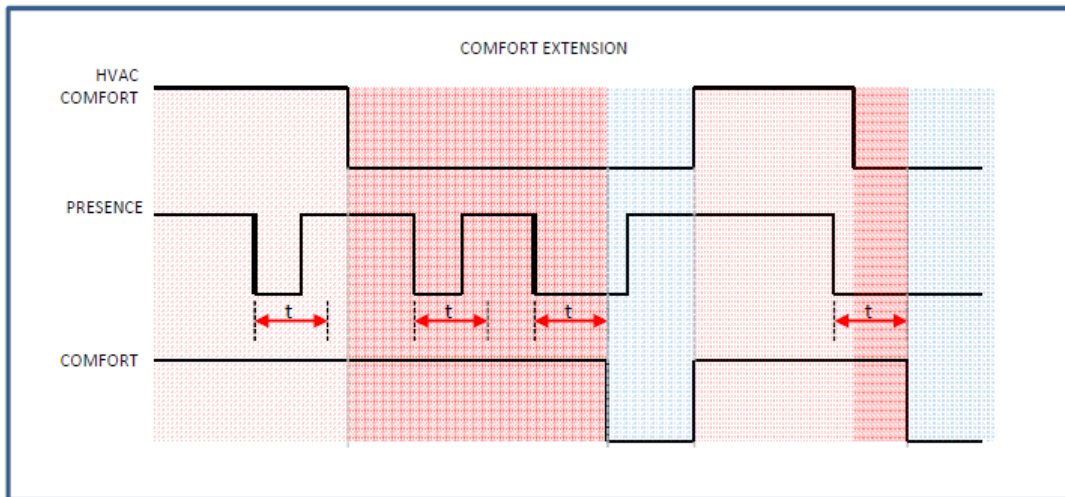

The figure above shows that, even if a presence is detected while the operating mode forced by the time scheduling function is not comfort, no change of operating mode is performed until the next programmed comfort event.

In case a forced HVAC mode is used by a supervisor through the communication object *HVAC forced mode* in DPT 20.102, the forced operating mode has a higher priority compared to the mode foreseen by the presence management, so it will prevail.

In case the energy saving management is carried out through window contacts, the latter has a higher priority compared to both the forced mode and the mode foreseen by the presence management; whatever operating mode is forced by the time scheduling function, by presence management or by forced mode, the system switches to building protection mode when detecting an open window.

Comfort limitation. This function is only active if the actual operating mode is set on comfort; if, during this time, a presence is not detected for a time period greater than a preset time, the operating mode shifts to economy or standby. The attenuation modes can be selected in the application program and are independent from the modes foreseen by the time scheduling function.

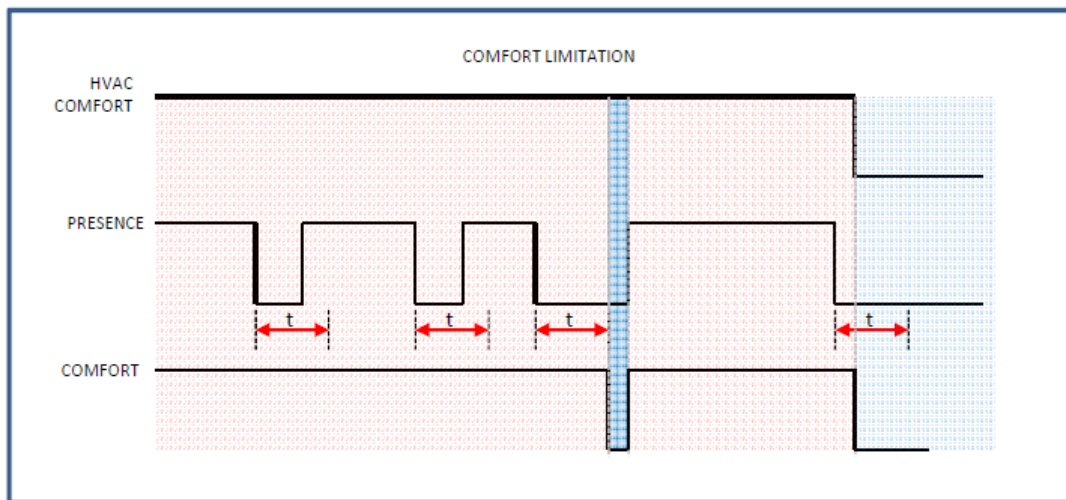

Same as comfort extension, in case a forced HVAC mode is used by a supervisor through the communication object *HVAC forced mode in DPT 20.102*, the forced operating mode has a higher priority compared to the mode foreseen by the presence management, so it will prevail.

In case the energy saving management is carried out through window contacts, the latter has a higher priority compared to both the forced mode and the mode foreseen by the presence management; whatever operating mode is forced by the time scheduling function, by presence management or by forced mode, the system switches to building protection mode when detecting an open window.

Comfort extension and comfort limitation. This mode is a combination of comfort extension and comfort limitation modes.

6.12 Valve protection

The distribution manifolds use water to transfer energy from the generators to the environments and are equipped with electrothermal actuators to intercept the hydraulic circuits. Under particular conditions, long inactivity periods can block those valves: to prevent this problem, the device can periodically activate an open/close cycle for the valves.

To perform such function, the device is equipped with a separated counter for each valve, which is activated every time the actuator completely closes the valve. When that counter reaches the value set in parameter *Frequency*, the valve is opened to prevent it from getting stuck. The duration of this opening depends on the value set in parameter *Time interval*. If the actuator brings the valve to fully open position before the time interval is reached, the counter is reset and then rebooted when the valve is closed again. The valve protection function is available when the device is configured both as actuator and as controller.

This function is available but not active in case of paired channel configuration (4-pipe) and output interlock active in order to prevent heating and cooling fluids from mixing together.

6.13 Forced mode outputs

It is possible to force from bus, through a supervisor, all or some outputs in a predefined state (on/off) or percentage value (0,.. 100%). This function is useful, for example, in case of plant maintenance. A general communication object, forcing all enabled outputs, is available, as well as another that operates a selective forcing on each individual output.

7 Application program for ETS

In the following chapters, there is the list of folder, parameters and communication objects of the application program.

i The parameter values **highlighted in bold** represent the *default* value.

The device paramers are divided in general parameters and specific parameters. They are grouped in folders. The following figure shows the tree structure of the application program, with the main folders:

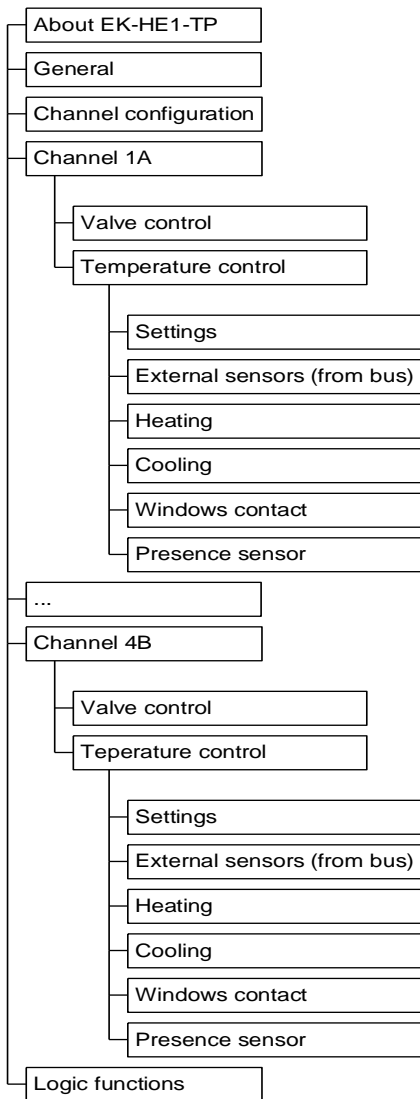

7.1 About EK-HE1-TP

The folder **About EK-HE1-TP** is for information purposes only and does not contain parameters to be set. The information given is:

© Copyright SBS S.p.A. 2016
Software applicativo per ETS4 & ETS5
Versione 1.00 (o successive)
EK-HE1-TP - actuator/controller 8 channels for electrothermal valve drives

SBS S.p.A.
Via Circonvallazione s/n
I-28010 Miasino (NO) Italy
www.ekinex.com
info@ekinex.com

7.2 General

This folder contains the general settings for the device configuration:

- Function: heating, cooling and both heating and cooling
- Actuator type: NO (normally open) or NC (normally closed)
- Short-circuit control: supply voltage selection
- Output activation delay: selection of delay between activations
- Manual operation: disable from bus, restore auto-mode time
- Supply voltage fault
- Logic functions
- Delay after bus voltage recovery

Parameter name	Conditions	Values
Function		cooling heating heating and cooling
	<i>This function is related to the distribution manifold application where the device is installed. Depending on the selected function, specific device characteristics are activated (for example, 4-pipe paired channel configuration, automatic switchover of conduction modes based on room temperature).</i>	
Actuator type		NC (normally closed) NO (normally open)
	<i>This selection is unique for all 8 device channels and cannot be individually selected for each channel.</i>	
Output activation delay		disabled enabled
	<i>This parameter allows to delay the output activation in order to avoid current peaks that may happen when multiple actuators are powered up at the same time. Please remind that the power supplied to NC actuators determines the aperture of corresponding valves; instead, it determines the closing of those valves used in combination with NO actuators.</i>	
Output delay	Output activation delay = enabled	5 s, 10 s, 15 s , 20 s, 25 s, 30 s, 35 s, 40 s
Changeover read on initialization	Function = heating and cooling	no / yes
	<i>This parameter allows the device to automatically synchronize after bus voltage recovery, without waiting for the c.o. indicating the current conduction mode to be sent.</i>	
[...]		

Parameter name	Conditions	Values
Manual operation		disabled enabled
Disable from bus	Manual operation = enabled	no / yes
Restore auto mode time (0 means no automatic restoring)	Manual operation = disabled	00:15:00 hh:mm:ss [range 00:00:00 ... 18:12:15]
[...]		
Short circuit control		disabled enabled
Supply voltage		230 Vac 24 Vac
	<i>In order for the power supply fault alarm to activate correctly, supply voltage must be properly configured to be consistent with the actual voltage delivered to the terminals and compatible with the used electrical actuators and/or servo motors. A wrong supply voltage configuration can lead to a continuous alarm condition and a faulty behavior of the EK-HE1-TP product.</i>	
Power status feedback		disabled enabled
	<i>Enables the exposition of those c.o. indicating power supply status to other bus devices. This alarm is always enabled.</i>	
[...]		
Logic functions		disabled enabled
[...]		
Delay after bus voltage recovery		00:00:05 hh:mm:ss [range 00:00:00 ... 18:12:15]
	<i>This parameter selects the delay from bus power-up to data transmission (status feedback, control output, etc.). This delay must be carefully selected in order to prevent, after a power supply fault and subsequent recovery, all devices from starting to communicate simultaneously, causing the available bandwidth to overload.</i>	

Object name	Conditions	Dim.	Flags	DPT	No. Comm. Obj.
Enable general forced mode from bus		1 Bit	C-W---	[1.003] enable	10
Test mode activated	Manual operation = enabled	1 Bit	CR-T--	[1.003] enable	13
Energy request (heating)	Energy request = enabled and Function = heating or both heating and cooling (4-pipe)	1 Bit	CR-T--	[1.001] switch	14
Energy request (cooling)	Energy request = enabled and Function = cooling or both heating and cooling (4-pipe)	1 Bit	CR-T--	[1.001] switch	15
Technical alarm		1 Bit	CR-T--	[1.005] alarm	16

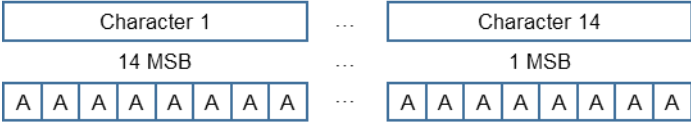
Object name	Conditions	Dim.	Flags	DPT	No. Comm. Obj.
Communication alarm		1 Bit	CR-T--	[1.005] alarm	17
Thermal generator lock alarm		1 Bit	CR-T--	[1.005] alarm	18
Short circuit alarm	Short circuit control = enabled	1 Bit	CR-T--	[1.005] alarm	19
Power off alarm output 1A, 1B, 2A and 2B	Power off alarm = enabled and at least 1 channel (1-4) enabled	1 Bit	CR-T--	[1.005] alarm	20
Power off alarm output 3A, 3B, 4A and 4B	Power off alarm = enabled and at least 1 channel (5-8) enabled	1 Bit	CR-T--	[1.005] alarm	21
Alarm text		14 Bytes	CR-T--	[16.000] Character String (ASCII)	22
 <p style="text-align: center;"> Character 1 ... Character 14 14 MSB ... 1 MSB A A A A A A A A A A A A A A A A </p> <p><i>This DPT is used to transmit the alarm as an ASCII string. The maximum length of the string is 14 characters (14 bytes). The string is sent starting from more significant character (14 MSB). If the string length is less than 14 characters, all unused bytes are filled with NULL character (00h). For example: "EKINEX is OK" is represented in the following way: 45h 4Bh 49h 4Eh 45h 58h 20h 69h 73h 20h 4Fh 4Bh 00h 00h</i></p>					
Disable front keyboard	Manual operation = enabled, Disable from bus = enabled	1 Bit	C-W---	[1.002] boolean	23

7.3 Channel configuration

This folder contains the settings to configure the specific function of each output (xA and xB) composing a channel (with x=1... 4).

In *General* \Rightarrow *Function* = heating or cooling, it is possible to independently configure each output, while in *General* \Rightarrow *Function* = *heating and cooling* it is possible to choose if keeping the 2 outputs independent or configuring them as 4-pipe:

- *Installation type* – Channel x = 2 independent channels (2 pipes) or
- *Installation type* – Channel x = 2 coupled channels (4 pipes)

Each independent output can be configured in one of the following ways:

- Disabled
- External controller
- Internal controller
- In parallel. The output is put in parallel to another selected output, limiting its operation to only one active conduction mode (heating or cooling only)
- Output command. The output is managed through a communication object to fulfill auxiliary functions.

Coupled outputs are suitable for 4-pipe distribution configurations; in this case, output xA manages the heating valve while output xB manages the cooling. The possible configuration choices are:

- Disabled
- External controller
- Internal controller

Other configurable parameters are:

- Command object timeout. This parameter is exposed when at least one output is configured as external controller
- Setpoint management: single, absolute or relative. This parameter is exposed when at least one output is configured as internal controller. This selection is common for all configured controllers.
- Energy request: on event or cyclic

Parameter name	Conditions	Values
Installation type – Channel x	General \Rightarrow Function = heating and cooling	2 independent channels 2 coupled channels (4 pipes)
	<i>4-pipe configuration is possible only if function is set on both heating and cooling.</i>	
Regulator	Installation type - channel (x) = 2 coupled channels (4 pipes)	disabled external controller internal controller
Channel xA (x=from 1 to 4)	Installation type - channel (x) = 2 independent channels (2 pipes)	disabled external controller internal controller in parallel (*) output command
	<i>(*) Parallel option is not present in channel 1A.</i>	
Channel xB (x=from 1 to 4)	Installation type - channel (x) = 2 independent channels (2 pipes)	disabled external controller internal controller in parallel output command

Parameter name	Conditions	Values
With	Installation type - channel (x) = 2 independent channels (2 pipes) and Channel (xA/B) = in parallel and x > 1A	channel 1A , channel 1B, channel 2A, channel 2B, channel 3A, channel 3B, channel 4A, channel 4B
	<i>For each channel xA/B where this option is selected, the possible choices are only among its previous channels, not among its next.</i>	
Function	Channel (x) – Installation type = 2 independent channels (2 pipes), Channel (xA/B) = in parallel and x > 1A and General ⇒ Function = heating and cooling	cooling heating heating and cooling
	<i>This function, in plants supporting both heating and cooling, allows to enable channel operation only in one specific conduction mode. For example, in a floor radiant plant, while in heating only a few coils are activated, in order to make a wider step. While in cooling, all coils are activated in order to achieve a better performance.</i>	
[...]		
Command object timeout	At least one Channel (xA/B) = external controller	00:05:00 hh:mm:ss [range 00:00:00 ... 18:12:15]
	<i>This parameter allows disabling the actuator outputs and generating a communication alarm if the object or command objects are not updated within the timeout set. The field has the format hh:mm:ss (hours:minutes:seconds). The default 0:05:00 therefore corresponds to a 5 minute timeout. The 00:00:00 means that the update control for command objects is disabled.</i>	
Setpoint management	At least one Channel (xA/B) = internal controller	single absolute relative
	<i>In case "single" option is selected and Function = heating, the temperature controller operates in heating conduction mode; in case Function = cooling, the temperature controller operates in cooling conduction mode. In case Function = heating and cooling, the current conduction mode has to be specified using the proper c.o.</i>	
Energy request		disabled enabled
	<i>Energy request heating and/or Energy request cooling c.o. evaluate the logical OR among all requests coming from active channels.</i>	
Energy request on delay [s]	Energy request = enabled	0 s [range 0 ... 255 s]
	<i>Value 0 means no delay in energy request status evaluation. This parameter allows to send a delayed energy request in order to make the actuators complete a full opening cycle (for example, to avoid that the circulator forces its hydraulic head on closed circuits).</i>	
Energy request send on initialization	Energy request = enabled	no / yes
Cyclic sending interval	Energy request = enabled	no sending [other values in the range 30 s ... 120 min]

Object name	Conditions	Dim.	Flags	DPT	No. Comm. Obj.
Heating/cooling changeover command (2 pipes)	Function = heating, cooling or both heating and cooling and Installation type = 2 pipes	1 Bit	C-WTU-	[1.100] heating/cooling	0
Heating/cooling changeover status (2 pipes)		1 Bit	CR-T--	[1.100] heating/cooling	1
Heating/cooling changeover command (4 pipes) – channel x		1 Bit	C-WTU-	[1.100] heating/cooling	2, 4, 6, 8

<i>Object name</i>	<i>Conditions</i>	<i>Dim.</i>	<i>Flags</i>	<i>DPT</i>	<i>No. Comm. Obj.</i>
Heating/cooling changeover status (4 pipes) – channel x	Installation type Channel x = 4 pipes	1 Bit	CR-T--	[1.100] heating/cooling	3, 5, 7, 9
On/off output command – channel xA/B	Channel xA/B = output command	1 Bit	C-W---	[1.001] switch	24, 49, 74, 99, 124, 149, 174, 199

7.4 Channel xA/B – Valve control / Channel x – Valve control heating/cooling

The *Valve control* folder is only active when the channel is configured as actuator with external controller. If, in the *Channel configuration* folder, a channel is configured as *in parallel*, the *Valve control* folder is not active. Exposed parameters include:

- Command communication object format: bit [DPT 1.001 switch] or byte [DPT 5.001 percentage]
- Valve position when command is not updated or after timeout
- In both heating and cooling application, operation limitation to one of the 2 conduction modes
- The outputs contributes to energy request or not
- PWM operation settings with byte command: cycle time, min and max control value
- Disable from bus
- Valve protection cycle activation
- Interlock activation (4-pipe configurations)

Parameter name	Conditions	Values
Command communication object format		output status [DPT 1.001] percentage [DPT 5.001]
Valve position after timeout	Command communication object format = output status [DPT 1.001]	off / on
Valve position after timeout	Command communication object format = output status [DPT 5.001]	50 % [other values in the range OFF... 100 %]
Command read on init		no / yes
Function	General ⇒ Function = heating and cooling	cooling heating heating and cooling
	<i>This function, in plants supporting both heating and cooling, allows to enable channel operation only in one specific conduction mode. For example, in a floor radiant plant, while in heating only a few coils are activated, in order to make a wider step. Wattivate solo alcune serpentine ottenendo un passo ampio. In cooling vengono invece attivate tutte le serpentine ottenendo una maggiore resa.</i>	
Energy request	General ⇒ Energy request = enabled	disabled enabled
	<i>Energy request heating and/or Energy request cooling c.o. evaluate the logical OR among all requests coming from active channels.</i>	
PWM cycle time [min]	Command communication object format = percentage [DPT 5.001]	15 min [other values in the range 1 min...255 min]
Min control value [%]	Command communication object format = percentage [DPT 5.001]	15 % [other values in the range 0 %...30 %]
	<i>It allows to adapt the PWM cycle to actuators with long opening cycles. If control value is less than set, NC actuators remain off, NO actuators remain on.</i>	
Max control value [%]	Command communication object format = percentage [DPT 5.001]	85 % [other values in the range 70 %... 100 %]
	<i>It allows to adapt the PWM cycle to actuators with long opening cycles. If control value is less than set, NC actuators remain on, NO actuators remain off.</i>	
Disable from bus		no / yes

Parameter name	Conditions	Values
Signal disable from bus	Disable from bus = yes	not inverted inverted
Enable forced mode from bus		no / yes
Valve position in forced mode	Enable forced mode from bus = yes and Command communication object format = output status [DPT 1.001]	off / on
Valve position in forced mode [%]	Enable forced mode from bus = yes and Command communication object format = output status [DPT 5.001]	50 % [other values in the range OFF...100 %]
[...]		
Valve protection function		disabled enabled
	<i>It enables the function that activates the drive for the valve control during periods of inactivity of the system.</i>	
Frequency	Valve protection function = enabled	once a day, once a week , once a month
Time interval	Valve protection function = enabled	10 s [other values in the range 5 s ... 20 min]
[...]		
Interlock function	General ⇒ Installation type = 4 pipes	disabled enabled
	<i>This parameter is present only in channel xA, its settings are valid also for corresponding channel xB.</i>	
Valve opening time [s]	General ⇒ Installation type = 4 pipes, Interlock function = enabled	100 s [range 0 ... 255 s]
	<i>This parameter is present only in channel xA, its settings are valid also for corresponding channel xB.</i>	

Object name	Conditions	Dim.	Flags	DPT	No. Comm. Obj.
Valve on/off command – channel xA/B	General ⇒ Installation type = 2 pipes and Command communication object format = output status [DPT 1.001]	1 Bit	C-WTU-	[1.001] switch	24, 49, 74, 99, 124, 149, 174, 199
Valve continuous command – channel xA/B	General ⇒ Installation type = 2 pipes and Command communication object format = percentage [DPT 5.001]	1 Byte	C-WTU-	[5.001] percentage (0..100%)	24, 49, 74, 99, 124, 149, 174, 199
Valve on/off heating command – channel xA	General ⇒ Installation type = 4 pipes and Command communication object format = output status [DPT 1.001]	1 Bit	C-WTU-	[1.001] switch	24, 74, 124, 174

<i>Object name</i>	<i>Conditions</i>	<i>Dim.</i>	<i>Flags</i>	<i>DPT</i>	<i>No. Comm. Obj.</i>
Valve continuous heating command – channel xA	General ⇒ Installation type = 4 pipes and Command communication object format = percentage [DPT 5.001]	1 Byte	C-WTU-	[5.001] percentage (0..100%)	24, 74, 124, 174
Valve on/off cooling command – channel xB	General ⇒ Installation type = 4 pipes and Command communication object format = output status [DPT 1.001]	1 Bit	C-WTU-	[1.001] switch	49, 99, 149, 199
Valve continuous cooling command – channel xB	General ⇒ Installation type = 4 pipes and Command communication object format = percentage [DPT 5.001]	1 Byte	C-WTU-	[5.001] percentage (0..100%)	49, 99, 149, 199

7.5 Channel x - xA/B – Temperature control

7.5.1 Settings

The *Settings* folder contains the parameter allowing to perform the basic configuration of the room temperature controller:

- setpoint type selection: single, absolute or relative;
- conduction mode changeover;
- antiscuff protection activation(2-pipe plants);
- output interlock activation (4-pipe plants).

This folder is active if the corresponding channel is configured as *internal controller* in *Channel configuration* folder.

Parameter name	Conditions	Values
Function	Channel configuration = Installation type - channel x = 2 independent channels and Channel xA/B = internal controller	cooling heating heating and cooling
Setpoint cyclic sending interval		no sending [other values in the range 30 s ... 120 min]
	<i>In case Setpoint type = single, the actual setpoint value takes only into account the actual state of the contacts window (if the corresponding function is enabled). In case Setpoint type = absolute or relative, the actual setpoint value also depends on the operating mode set automatically by another KNX supervising device with the possibility of time scheduling.</i>	
Heating/cooling changeover	Channel configuration = Installation type - channel x = 2 coupled channels (4 pipes) and Channel x = internal controller	from bus automatic from room temperature
End time manual setpoint		till first telegram from bus [other values in the range 30 min ... 48 h]
	<i>Defines forced/manual mode exit mode</i>	
Interlock function	Channel configuration = Installation type - channel x = 2 coupled channels (4 pipes) and Channel x = internal controller	disabled enabled
	<i>This parameter is only active in channel xA, it is not enabled in channel xB.</i>	
Valve opening time [s]	Channel configuration = Installation type - channel x = 2 coupled channels (4 pipes) and Channel x = internal controller and Interlock function = enabled	100 s [range 0 ... 255 s]
	<i>This parameter is only active in channel xA, it is not enabled in channel xB.</i>	
[...]		
Valve protection function	Channel configuration = Installation type - channel x = 2 independent channels and Channel xA/B = internal controller	disabled enabled
	<i>It enables the function that activates the drive for the valve control during periods of inactivity of the system.</i>	
Frequency	Valve protection function = enabled	once a day, once a week, once a month

Parameter name	Conditions	Values
Time interval	Valve protection function = enabled	10 s [other values in the range 5 s ... 20 min]
[...]		
Disable from bus	Channel configuration = Installation type - channel x = 2 independent channels and Channel xA/B = internal controller	no / yes
Signal disable from bus	Channel configuration = Installation type - channel x = 2 independent channels and Channel xA/B = internal controller and Disable from bus = yes	not inverted inverted
Enable forced mode from bus	Channel configuration = Installation type - channel x = 2 independent channels and Channel xA/B = internal controller	no / yes
Valve position in force mode	Channel configuration = Installation type - channel x = 2 independent channels and Channel xA/B = internal controller and Enable forced mode from bus = yes	off / on
Enables valve position feedback	Channel configuration = Installation type - channel x = 2 independent channels and Channel xA/B = internal controller	no / yes
Cyclic sending interval	Channel configuration = Installation type - channel x = 2 independent channels and Channel xA/B = internal controller and Enables valve position feedback = yes	no sending [other values in the range 30 s ... 120 min]
Min change of value to send [%]	Channel configuration = Installation type - channel x = 2 independent channels and Channel xA/B = internal controller and Enables valve position feedback = yes and Control type = PWM	10 [other values in the range 0 ... 100 %]

Object name	Conditions	Dim.	Flags	DPT	No. Comm. Obj.
Actual setpoint – channel x – xA/B		2 Byte	CR-T--	[9.001] temperature (°C)	38, 63, 88, 113, 138, 163, 188, 213
Heating/cooling changeover command (4 pipes) – channel x	General ⇒ Installation type = 4 pipes and Heating/cooling changeover = from bus	1 Bit	C-WTU-	[1.100] heating/cooling	2, 4, 6, 8
<i>The communication object is received from the bus. At the switching event, the internal regulator switches the conduction mode.</i>					

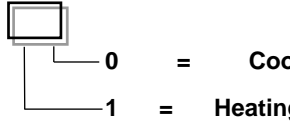
Object name	Conditions	Dim.	Flags	DPT	No. Comm. Obj.
Heating/cooling changeover status (4 pipes) – channel x	General ⇒ Installation type = 4 pipes and Heating/cooling changeover = automatic from room temperature	1 Bit	CR-T--	[1.100] heating/cooling	3, 5, 7, 9
<p>The communication object is updated on the bus on event of change internally elaborated by the controller.</p> <p>[1.100] DPT Heat/Cool 1 Bit</p> 					
HVAC mode in – channel x – xA/B	Setpoint management ≠ Single	1 Byte	C-W---	[20.102] HVAC mode	34, 59, 84, 109, 134, 159, 184, 209
<p>Bits 5 to 8 are reserved.</p> <p>[20.102] DPT HVAC Mode 1 Byte</p> <p style="text-align: center;"> AUTO COMFORT STAND-BY </p> <p style="text-align: center;"> 0 0 0 0 0 0 0 1 0 0 1 0 </p> <p style="text-align: center;"> ECONOMY PROTECTION </p> <p style="text-align: center;"> 0 0 1 1 0 1 0 0 </p>					
HVAC manual mode – channel x – xA/B	Setpoint management ≠ Single	1 Byte	C-W---	[20.102] HVAC mode	35, 60, 85, 110, 135, 160, 185, 210
Chrono active status – channel x – xA/B	Setpoint management ≠ Single	1 Bit	CRWTU-	[1.011] state	36, 61, 86, 111, 136, 161, 186, 211
HVAC mode out – channel x – xA/B	Setpoint management ≠ Single	1 Byte	C-W---	[20.102] HVAC mode	37, 62, 87, 112, 137, 162, 187, 212
Valve disable from bus – channel xA/B	2 pipes configuration and Disable from bus = yes	1 Bit	C-W---	[1.003] enable	25, 50, 75, 100, 125, 150, 175, 200
Enable forced mode from bus – channel xA/B	2 pipes configuration and Enable forced mode from bus = yes	1 Bit	C-W---	[1.003] enable	26, 51, 76, 101, 126, 151, 176, 201
Valve on/off status – channel xA/B	2 pipes configuration and Enables valve position feedback = yes	1 Bit	C-W---	[1.003] enable	24, 49, 74, 99, 124, 149, 174, 199

7.5.1.1 Monitoring and remote command of the conduction mode

The communication objects indicated in the block diagram allows monitoring and modifying the current conduction mode forced on the temperature controller. The object 20 – *Heating/cooling status out* is always exposed, even when the thermostat function is set on heating or cooling only. When the function is set on both

heating and cooling, the cyclic sending on bus can be enabled; anyway, the information about the actual conduction mode can be acquired with a reading request to this communication object.

The object 43 – *Heating/cooling status in* is exposed only when the function is both heating and cooling and the switching among the different modes is performed by the bus.

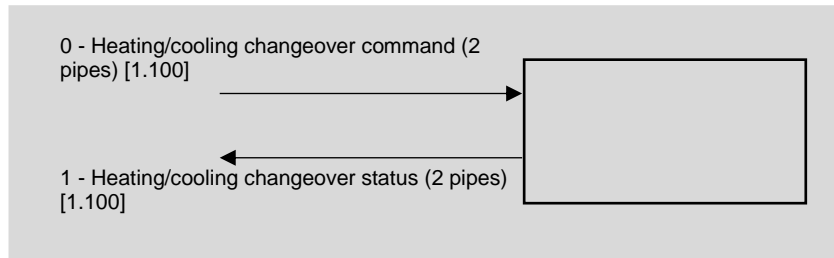

7.5.1.2 Remote operating mode modification

The communication objects shown in figure allow monitoring the operating mode (comfort, standby, economy and building protection) modifications performed by a supervisor software or the operating mode forced by chrono program.

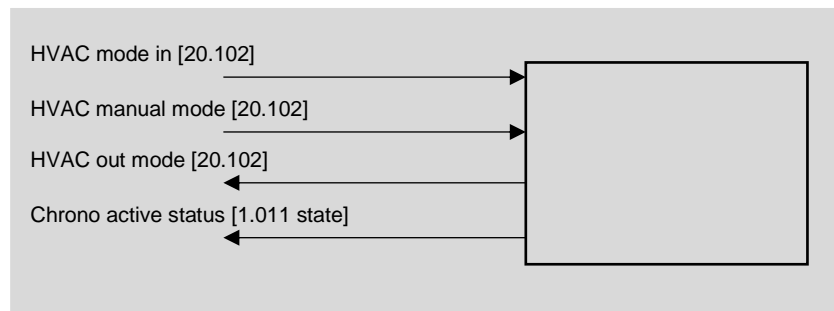

The C.O. 22 – *HVAC mode in* is associated to the chrono program. The C.O.s 24 – *HVAC mode out* and 26 – *HVAC chrono active status* allow the remote supervisor to discern the operating mode currently active on the room thermostat and also allow to understand if the chrono program is active or if attenuation is handled manually or not. The supervisor can set at any time a manual operating mode through C.O. 25 – *HVAC manual mode*; to start the chrono program remotely, the C.O. 25 – *HVAC manual mode* is to be set on value 0 = Automatic.

7.5.2 External sensors (from bus)

The possibility to connect external KNX sensors via KNX bus extends the device capabilities. This folder is only active when the device is configured as actuator/controller (*Channel configuration* = internal controller).

Parameter name	Conditions	Values
Room temperature 1		enabled
Cyclic reading interval	Room temperature 1 = enabled	no reading [other values in the range 30 s ... 120 min]
	<i>If this parameter is configured as "no reading", the corresponding c.o. must be updated on the remote device which is sending data. With different settings, data are updated with a reading request.</i>	
Room temperature 2		disabled enabled
Cyclic reading interval	Room temperature 2 = enabled	no reading [other values in the range 30 s ... 120 min]
	<i>If this parameter is configured as "no reading", the corresponding c.o. must be updated on the remote device which is sending data. With different settings, data are updated with a reading request.</i>	
Relative weight	Room temperature 2 = enabled	100% room temperature 1 90% / 10% 80% / 20% 70% / 30% 60% / 40% 50% / 50% 40% / 60% 30% / 70% 20% / 80% 10% / 90% 100% room temperature 2
Floor temperature		disabled enabled
Cyclic reading interval	Floor temperature = enabled	no reading [other values in the range 30 s ... 120 min]
	<i>If this parameter is configured as "no reading", the corresponding c.o. must be updated on the remote device which is sending data. With different settings, data are updated with a reading request.</i>	
Analog sensors timeout		00:05:00 hh:mm:ss [range 00:00:00 ... 18:12:15]
	<i>The field has the format hh:mm:ss (hours:minutes:seconds): the default value 00:05:00 therefore corresponds to a 5 minute timeout. The 00:00:00 means that the time-out of analog sensors is deactivated.</i>	
Anticondensation		disabled enabled
	<i>It enables a bus sensor for condensation detection.</i>	
Signal	Anticondensation = enabled	not inverted / inverted
Cyclic reading interval	Anticondensation = enabled	no reading [other values in the range 30 s ... 120 min]

Parameter name	Conditions	Values
Window contact		disabled enabled
	<i>It enables a bus sensor for detecting the open/close status of a door or window.</i>	
Signal	Window contact = enabled	not inverted / inverted
Cyclic reading interval	Window contact = enabled	no reading [other values in the range 30 s ... 120 min]
Presence sensor		disabled enabled
	<i>It enables a bus sensor for detecting the movement/presence of people inside an environment.</i>	
Signal	Presence sensor = enabled	not inverted / inverted
Cyclic reading interval	Presence sensor = enabled	no reading [other values in the range 30 s ... 120 min]
Digital sensors timeout		00:05:00 hh:mm:ss [range 00:00:00 ... 18:12:15]
	<i>The field has the format hh:mm:ss (hours:minutes:seconds): the default value 00:05:00 therefore corresponds to a 5 minute timeout. The 00:00:00 means that the time-out of digital sensors is deactivated.</i>	

Object name	Conditions	Dim.	Flags	DPT	No. Comm. Obj.
Room temperature 1 (from bus) – channel x – xA/B	enabled	2 Byte	C-WT-	[9.001] temperature (°C)	28, 53, 78, 103, 128, 153, 178, 203
Room temperature 2 (from bus) – channel x – xA/B	enabled	2 Byte	C-WT-	[9.001] temperature (°C)	29, 54, 79, 104, 129, 154, 179, 204
Floor surface temperature (from bus) – channel x – xA/B	enabled	2 Byte	C-WT-	[9.001] temperature (°C)	30, 55, 80, 105, 130, 155, 180, 205
Anticondensation sensor (from bus) – channel x – xA/B	enabled	1 Bit	C-WT-	[1.001] switch	31, 56, 81, 106, 131, 156, 181, 206
Windows contact sensor (from bus) – channel x – xA/B	enabled	1 Bit	C-WT-	[1.019] window/door	32, 57, 82, 107, 132, 157, 182, 207
Presence sensor (from bus) – channel x – xA/B	enabled	1 Bit	C-WT-	[1.018] occupancy	33, 58, 83, 108, 133, 158, 183, 208

7.5.3 Heating

The *Heating* folder allows setting:

- the default value for single or relative setpoint (comfort setpoint and standby / economy attenuations);
- the type of regulation algorithm

This folder is active if *Channel X = internal controller* and

General ⇒ *Function* = heating or both heating and cooling.

Parameter name	Conditions	Values
Temperature setpoint [°C]	Setpoint management = Single	21 [range 10 ... 50]
Comfort temperature setpoint [°C]	Setpoint management = Relative or absolute	21 [range 10 ... 50]
Standby temperature offset [0,1 K]	Setpoint management = Relative or absolute	- 30 [range -10 ... -50]
Economy temperature offset [0,1 K]	Setpoint management = Relative or absolute	-50 [range -10 ... -50]
Building protection temperature [°C]		7 [range 2 ... 10]
[...]	<i>Parameters regarding the type of control algorithm for the valves</i>	
Control type		2 points hysteresis, PWM (pulse width modulation)
Hysteresis	Control type = 2 points hysteresis	0,3 K [other values in the range 0,2 K ... 3 K]
Position	Heating type = floor radiant panels, ceiling radiant panels, Control type = 2 points hysteresis	below / above
	<i>The superior hysteresis is suitable for peculiar application which needs to control the mixing group.</i>	
PWM cycle time [min]	Control type = PWM (pulse with modulation)	15 min [range 5 ... 240 min]
Min control value [%]	Control type = PWM (pulse with modulation)	15 % [range 0 %...30 %]
Max control value [%]	Control type = PWM (pulse with modulation)	85 % [range 70 %...100 %]

Parameter name	Conditions	Values
Proportional band [0,1 K]	Control type = PWM (pulse with modulation)	30 (*) [range 0 ... 255]
	<p><i>This value is displayed in tenth of Kelvin (K) degrees.</i></p> <p><i>(*) This range contains a preset value depending on selected heating type (this value can be edited):</i></p> <ul style="list-style-type: none"> radiators: 50 (5 K) floor radiant panels: 50 (5 K) ceiling radiant panels: 50 (5 K) <p><i>The proportional band value represent the max difference between setpoint and measured temperature which determines the maximum control output.</i></p>	
Integral time [min]	Control type = PWM (pulse with modulation)	240 (*) [range 0 ... 255 min]
	<p><i>(*) This range contains a preset value depending on selected heating type (this value can be edited):</i></p> <ul style="list-style-type: none"> radiators: 150 min floor radiant panels: 240 min ceiling radiant panels: 180 min 	
[...]		
Heating type		radiators floor radiant panels ceiling radiant panels
	<p><i>It defines the terminal type used for heat exchange. This selection determines the default parameters for PWM control algorithm (proportional band and integral time) and control options.</i></p>	
Surface temperature limitation	Heating type = floor radiant panels, External sensors (from bus) ⇒ Radiant floor temperature sensor = enabled	disabled enabled
	<p><i>This parameter enables the surface temperature limitation function of a radiant floor. For this function, it is mandatory to measure the floor surface temperature by enabling the proper temperature sensor in External sensors (from bus) folder.</i></p> <p>Important. <i>This function does not substitute overheating protection, normally foreseen in floor radiant plants, where a safety thermostat is used.</i></p>	
Upper temperature limit [°C]	Surface temperature limitation = enabled	29 [range 20 ... 40]
	<p><i>EN 1264 indicates a maximum temperature for floor radiant panel surfaces:</i></p> <ul style="list-style-type: none"> <i>T(sup) max ≤ 29°C for normal occupancy zones;</i> <i>T(sup) max ≤ 35°C for peripheral zones.</i> <p><i>National regulations can also limit these temperatures to lower values. Peripheral zones are spaces (max 1 m) along the external walls of a building.</i></p>	
Hysteresis [K]	Surface temperature limitation = enabled	0,3 K [other values in the range 0,2 K ... 3 K]
	<p><i>The surface temperature has to drop below the set threshold plus an offset corresponding to the hysteresis value in order for the alarm to reset.</i></p>	
[...]		
Energy request	General ⇒ Energy request = enabled	disabled enabled
[...]		
Disable from bus	4 pipes configuration	no / yes

Parameter name	Conditions	Values
Signal disable from bus	4 pipes configuration and Disable valve from bus = yes	not inverted inverted
Enable forced mode from bus	4 pipes configuration	no / yes
Valve position in forced mode	4 pipes configuration and Enable forced mode from bus = yes and Control type = 2 points hysteresis	off / on
Valve position in forced mode [%]	4 pipes configuration and Enable forced mode from bus = yes and Control type = PWM	50 % [other values in the range OFF...100 %]
Enable valve position feedback	4 pipes configuration	no / yes
	<i>In case of position feedback enabling without cyclic sending, the CO is updated when the device starts and on change of state.</i>	
Cyclic sending interval	4 pipes configuration and Enables valve position feedback = yes	no sending [other values in the range 30 s ... 120 min]
Min change of value to send [%]	4 pipes configuration and Enables valve position feedback = yes and Control type = PWM	10 [other values in the range 0 ... 100 %]

Object name	Conditions	Dim.	Flags	DPT	No. Comm. Obj.
Actual setpoint – channel x – xA/B		2 Byte	CR-T--	[9.001] temperature (°C)	38, 63, 88, 113, 138, 163, 188, 213
Input setpoint – channel x – xA/B		2 Byte	C-W---	[9.001] temperature (°C)	41, 66, 91, 116, 141, 166, 191, 216
Comfort setpoint (heating) – channel x – xA/B		2 Byte	CRWTU-	[9.001] temperature (°C)	41, 66, 91, 116, 141, 166, 191, 216
Standby offset (heating) – channel x – xA/B		2 Byte	CRWTU-	[9.002] temperature difference (K)	43, 68, 93, 118, 143, 168, 193, 218
Standby setpoint (heating) – channel x – xA/B		2 Byte	CRWTU-	[9.001] temperature (°C)	43, 68, 93, 118, 143, 168, 193, 218
Economy offset (heating) – channel x – xA/B		2 Byte	CRWTU-	[9.002] temperature difference (K)	45, 70, 95, 120, 145, 170, 195, 200
Economy setpoint (heating) – channel x – xA/B		2 Byte	CRWTU-	[9.001] temperature (°C)	45, 70, 95, 120, 145, 170, 195, 200

Object name	Conditions	Dim.	Flags	DPT	No. Comm. Obj.
Building protection setpoint (heating) – channel x – xA/B		2 Byte	CRWTU-	[9.001] temperature (°C)	47, 72, 97, 122, 147, 172, 197, 222
Valve disable from bus – channel x – xA/B	2 pipes configuration	1 Bit	C-W---	[1.003] enable	25, 50, 75, 100, 125, 150, 175, 200
Heating valve disable from bus – channel xA	4 pipes configuration	1 Bit	C-W---	[1.003] enable	25, 75, 125, 175
Enable forced mode from bus – channel xA/B	2 pipes configuration	1 Bit	C-W---	[1.003] enable	26, 51, 76, 101, 126, 151, 176, 201
Enable heating forced mode from bus – channel xA	4 pipes configuration	1 Bit	C-W---	[1.003] enable	26, 76, 126, 176
Valve on/off status – channel xA/B		1 Bit	CR-T--	[1.001] switch	24, 49, 74, 99, 124, 149, 174, 199
Valve continuous status – channel xA/B		1 Byte	CR-T--	[5.001] percentage (0..100%)	24, 49, 74, 99, 124, 149, 174, 199
Valve on/off heating status – channel xA		1 Bit	CR-T--	[1.001] switch	24, 74, 124, 174
Valve continuous heating status – channel xA		1 Byte	CR-T--	[5.001] percentage (0..100%)	24, 74, 124, 174
Manual setpoint – channel x – xA/B		2 Byte	CRWTU-	[9.001] temperature (°C)	39, 64, 89, 114, 139, 164, 189, 214
Manual setpoint active status – channel x – xA/B		1 Bit	C-W---	[1.003] enable	40, 65, 90, 115, 140, 165, 190, 215

7.5.3.1 *Remote Setpoint modification*

The communication objects shown in figure allow to monitor the Setpoint forced modifications performed remotely, for example from a supervisor software.

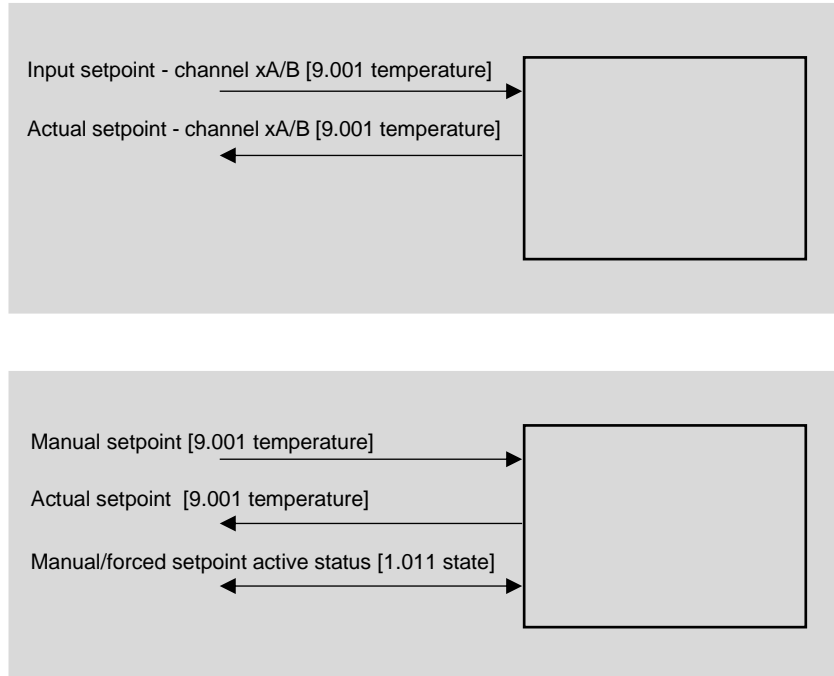

Those objects are about the Setpoint forced modification: alternatively, the supervisor can act directly on the operating mode setpoints (C.O. with index 50-57). The value of the C.O. *Actual setpoint* represents the current operative setpoint, which the control algorithms are based on. L'O.C. *Manual/forced setpoint active status* indicates if the forced mode is active. The supervisor can force at any time the actual setpoint by writing a new value directly into the C.O. *Manual setpoint*. The C.O. *Manual/forced setpoint active status* can also be used in writing to exit from the active forced mode.

7.5.4 Cooling

The *Cooling* folder allows setting:

- the default values for single or relative setpoints (comfort setpoint and standby / economy attenuations) in case of manual heating-cooling changeover;
- the default value for the dead-band for changeover and for standby / economy attenuations in case of automatic, based on internal conditions heating-cooling changeover;
- the type of regulation algorithm (2-point hysteresis, PWM) and internal parameters to control the valve.

This folder is active if *Channel X = internal controller* and

General ⇒ *Function* = cooling or both heating and cooling.

Parameter name	Conditions	Values
Temperature setpoint [°C]	Setpoint management = Single	23 [range 10 ... 50]
Dead band [0,1 K] (*)	Setpoint management = relative, Heating/cooling changeover = automatico	20 [range 10 ... 40]
Comfort temperature setpoint [°C]	Setpoint management = relative, Heating/cooling changeover = from bus	23 [range 10 ... 50]
Standby temperature offset [0,1 K]	Setpoint management = relative,	30 [range 10 ... 50]
Economy temperature offset [0,1 K]	Setpoint management = relative	50 [range 10 ... 80]
Building protection temperature [°C]		36 [range 20 ... 50]
[...]	<i>Parameters regarding the type of control algorithm for the valves</i>	
Control type		2 points hysteresis, PWM (pulse width modulation)
Hysteresis	Control type = 2 points hysteresis	0,3 K [other values in the range 0,2 K ... 3 K]
Position	Heating type = floor radiant panels, ceiling radiant panels, Control type = 2 points hysteresis	below / above
	<i>The superior hysteresis is suitable for peculiar application which needs to control the mixing group.</i>	
PWM cycle time [min]	Control type = PWM (pulse with modulation)	15 min [range 5 ... 240 min]
Min control value [%]	Control type = PWM (pulse with modulation)	15 % [range 0 %...30 %]

Parameter name	Conditions	Values
Max control value [%]	Control type = PWM (pulse with modulation)	85 % [range 70 %...100 %]
Proportional band [0,1 K]	Control type = PWM (pulse with modulation)	30 (*) [range 0 ... 255]
	<p><i>This value is displayed in tenth of Kelvin (K) degrees.</i></p> <p><i>(*) This range contains a preset value depending on selected heating type (this value can be edited):</i></p> <ul style="list-style-type: none"> • radiators: 50 (5 K) • floor radiant panels: 50 (5 K) • ceiling radiant panels: 50 (5 K) <p><i>The proportional band value represent the max difference between setpoint and measured temperature which determines the maximum control output.</i></p>	
Integral time [min]	Control type = PWM (pulse with modulation)	240 (*) [range 0 ... 255 min]
	<p><i>(*) This range contains a preset value depending on selected heating type (this value can be edited):</i></p> <ul style="list-style-type: none"> • radiators: 150 min • floor radiant panels: 240 min • ceiling radiant panels: 180 min 	
[...]		
Cooling type		radiant panels ceiling radiant panels
	<i>If Function = heating and cooling, the same settings of the heating folder are displayed.</i>	
Anticondensation protection	Cooling type = radiant panels, ceiling radiant panels, External sensors (from bus) ⇒ Anticondensation = enabled	disabled enabled
[...]		
Energy request	General ⇒ Energy request = enabled	no / yes
Disable from bus	General ⇒ Function = Cooling	no / yes
	<i>This c.o. is common for both heating and cooling mode. In case the plant is configured as both heating and cooling, this property is enabled in the heating folder only.</i>	
Signal disable from bus	Disable valve from bus = yes	not inverted inverted
Enable forced mode from bus	General ⇒ Function = Cooling	no / yes
	<i>This c.o. is common for both heating and cooling mode. In case the plant is configured as both heating and cooling, this property is enabled in the heating folder only.</i>	
Valve position in forced mode	Enable forced mode from bus = yes and Control type = 2 points hysteresis	off / on
Valve position in forced mode [%]	Enable forced mode from bus = yes and Control type = PWM	50 % [other values in ther range OFF...100 %]
Enables valve position feedback		no / yes
	<i>If position feedback without cyclic sending is enabled, this c.o. is updated every device power-up and every change of state.</i>	

Parameter name	Conditions	Values
Cyclic sending interval	Enables valve position feedback = yes	no sending [other values in the range 30 s ... 120 min]
Min change of value to send [%]	4 pipes configuration and Enables valve position feedback = yes and Control type = PWM	10 [other values in the range 0 ... 100 %]

Object name	Conditions	Dim.	Flags	DPT	No. Comm. Obj.
Actual setpoint – channel x – xA/B		2 Byte	CR-T--	[9.001] temperature (°C)	38, 63, 88, 113, 138, 163, 188, 213
Input setpoint – channel x – xA/B		2 Byte	C-W---	[9.001] temperature (°C)	41, 66, 91, 116, 141, 166, 191, 216
Comfort setpoint (cooling) – channel x – xA/B		2 Byte	CRWTU-	[9.001] temperature (°C)	42, 67, 92, 117, 142, 167, 192, 217
Standby offset (cooling) – channel x – xA/B		2 Byte	CRWTU-	[9.002] temperature difference (K)	44, 69, 94, 119, 144, 169, 194, 219
Standby setpoint (cooling) – channel x – xA/B		2 Byte	CRWTU-	[9.001] temperature (°C)	44, 69, 94, 119, 144, 169, 194, 219
Economy offset (cooling) – channel x – xA/B		2 Byte	CRWTU-	[9.002] temperature difference (K)	46, 71, 96, 121, 146, 171, 196, 221
Economy setpoint (cooling) – channel x – xA/B		2 Byte	CRWTU-	[9.001] temperature (°C)	46, 71, 96, 121, 146, 171, 196, 221
Building protection setpoint (cooling) – channel x – xA/B		2 Byte	CRWTU-	[9.001] temperature (°C)	48, 73, 98, 123, 148, 173, 198, 223
Valve disable from bus – channel x – xA/B	2 pipes configuration	1 Bit	C-W---	[1.003] enable	25, 50, 75, 100, 125, 150, 175, 200
Cooling valve disable from bus – channel xB	4 pipes configuration	1 Bit	C-W---	[1.003] enable	25, 50, 75, 100, 125, 150, 175, 200
Enable forced mode from bus – channel xA/B	2 pipes configuration	1 Bit	C-W---	[1.003] enable	26, 51, 76, 101, 126, 151, 176, 201
Enable cooling forced mode from bus – channel xB	4 pipes configuration	1 Bit	C-W---	[1.003] enable	51, 101, 151, 201
Valve on/off status – channel xA/B		1 Bit	CR-T--	[1.001] switch	24, 49, 74, 99, 124, 149, 174, 199

<i>Object name</i>	<i>Conditions</i>	<i>Dim.</i>	<i>Flags</i>	<i>DPT</i>	<i>No. Comm. Obj.</i>
Valve continuous status – channel xA/B		1 Byte	CR-T--	[5.001] percentage (0..100%)	24, 49, 74, 99, 124, 149, 174, 199
Valve on/off cooling status – channel xB		1 Bit	CR-T--	[1.001] switch	49, 99, 149, 199
Valve continuous cooling status – channel xB		1 Byte	CR-T--	[5.001] percentage (0..100%)	49, 99, 149, 199
Manual setpoint – channel x – xA/B		2 Byte	CRWTU-	[9.001] temperature (°C)	39, 64, 89, 114, 139, 164, 189, 214
Manual setpoint active status – channel x – xA/B		1 Bit	C-W---	[1.003] enable	40, 65, 90, 115, 140, 165, 190, 215

7.5.5 Windows contacts

This folder is active if the controller is set on internal (*Channel X = internal controller*) and if a contact is detected through the proper communication object (folder *External sensors from bus*).

Parameter name	Conditions	Values
Windows contact function		disabled enabled
Wait time to building protection mode	Window contacts function = enabled	00:01:00 hh:mm:ss [range 00:00:00 ... 18:12:15]
	<i>Time interval before the automatic switching of the device to the Building protection operating mode</i>	

Object name	Conditions	Dim.	Flags	DPT	No. Comm. Obj.
Windows contact sensor (from bus) – channel x – xA/B	Window contacts function = enabled	1 Bit	C-WT-	[1.019] window/door	32, 57, 82, 107, 132, 157, 182, 207

7.5.6 Presence sensors

This folder is active if the controller is set on internal (*Channel X = internal controller*) and if a contact is detected through the proper communication object (folder *External sensors from bus*).

Parameter name	Conditions	Values
Presence sensor function		disabled enabled
<i>Parameter that enables the presence sensor function.</i>		
Presence sensors use	Presence sensor function = enabled	comfort extension comfort limitation comfort extension and comfort limitation
Thermostat modes	Presence sensor function = enabled Presence sensors use = comfort extension and comfort limitation or = comfort limitation	comfort-standby comfort-economy
Absence time to switch HVAC mode	Presence sensor function = enabled	00:01:00 hh:mm:ss [range 00:00:00 ... 18:12:15]

Object name	Conditions	Dim.	Flags	DPT	No. Comm. Obj.
Presence sensor (from bus) – channel x – xA/B	Presence sensor function = enabled	1 Bit	C-WT-	[1.018] occupancy	33, 58, 83, 108, 133, 158, 183, 208

7.6 Logic functions

The actuator/controller (EK-HE1-TP version) allows using some useful logic functions (AND, OR, NOT and exclusive OR) in order to implement complex functions in the building automation system.

You can configure:

- 4 channels of logical functions
- 4 inputs for each channel

Each object value, if desired, can be individually inverted by inserting a NOT logic operator.

For each channel, a parameter *Delay after bus voltage recovery* is available: this parameter represents the time interval between the bus voltage recovery and the first reading of the input communication objects for evaluating the logic functions.



In case of incorrect connection of the input communication object or electrical trouble on bus resulting in a failed input reading request, the logic output of the corresponding channel can be calculated by setting the input values to default.

The communication function representing the logic function output is sent on the bus on event of change; alternatively, a cyclic sending can be set.

The folder is enabled if: *General* ⇒ *Logic functions* = enabled.

Parameter name	Conditions	Values
Logic function		disabled enabled
Logic operation	Logic function = enabled	OR / AND / XOR
	<i>XOR (eXclusive OR)</i>	
Delay after bus voltage recovery		00:00:04.000 hh:mm:ss.fff [range 00:00:00.000 ... 00:10:55.350]
	<i>Time interval between the bus voltage recovery and the first reading of the input communication objects for evaluating the logic functions.</i>	
Output cyclic transmission interval		no sending [other values in the range 30 s ... 120 min]
	<i>No sending means that the output state of the logic function is updated on the bus only on change. Different values imply cyclic sending on the bus of the output state.</i>	
Logic object x		disabled enabled
Logic object x negated	Logic object x = enabled	no / yes
	<i>By denying the logic state of the corresponding object, it is possible to create complex combinatory logics. For example: Output= (NOT(Logic object 1) OR Logic object 2).</i>	
Logic object x read at startup	Logic object x = enabled	no / yes
Logic object x default value	Logic object x = enabled	none / off / on

<i>Object name</i>	<i>Conditions</i>	<i>Dim.</i>	<i>Flags</i>	<i>DPT</i>	<i>No. Comm. Obj.</i>
Logic function X, Input 1	Logic function X = enabled Logic object 1 = enabled	1 Bit	C-WTU-	[1.001] switch	224, 229, 234, 239
Logic function X, Input 2	Logic function X = enabled Logic object 2 = enabled	1 Bit	C-WTU-	[1.001] switch	225, 230, 235, 240
Logic function X, Input 3	Logic function X = enabled Logic object 3 = enabled	1 Bit	C-WTU-	[1.001] switch	226, 231, 236, 241
Logic function X, Input 4	Logic function X = enabled Logic object 4 = enabled	1 Bit	C-WTU-	[1.001] switch	227, 232, 237, 242
Logic function X, Output	Logic function X = enabled	1 Bit	CR-T--	[1.001] switch	228, 233, 238, 243

8 Appendix

8.1 List of KNX communications objects

The following list contains the KNX communication objects for all corresponding *Data Point Types* (DPT) defined by the application program according to the performed configurations.

The list is ordered by object number; if the same object is linked to different inputs, the first input or rocker is referenced.

Nr.	Object name di comunicazione	Dimensione	Flag	Tipo DataPoint
0	Heating/cooling changeover command (2 pipes)	1 Bit	-WCTU-	[1.100] DPT_Heat_Cool
1	Heating/cooling changeover status (2 pipes)	1 Bit	R-CT--	[1.100] DPT_Heat_Cool
2, 4, 6, 8	Heating/cooling changeover command (4 pipes) – channel x	1 Bit	-WCTU-	[1.100] DPT_Heat_Cool
3, 5, 7, 9	Heating/cooling changeover status (4 pipes) – channel x	1 Bit	R-CT--	[1.100] DPT_Heat_Cool
10	Enable general forced mode from bus	1 Bit	-WC---	[1.3] DPT_Enable
13	Test mode activated	1 Bit	R-CT--	[1.3] DPT_Enable
14	Energy request (heating)	1 Bit	R-CT--	[1.1] DPT_Switch
15	Energy request (cooling)	1 Bit	R-CT--	[1.1] DPT_Switch
16	Technical alarm	1 Bit	R-CT--	[1.5] DPT_Alarm
17	Communication alarm	1 Bit	R-CT--	[1.5] DPT_Alarm
18	Thermal generator lock alarm	1 Bit	-WC---	[1.5] DPT_Alarm
19	Short circuit alarm	1 Bit	R-CT--	[1.5] DPT_Alarm
20	Power off alarm output 1A, 1B, 2A and 2B	1 Bit	R-CT--	[1.5] DPT_Alarm
21	Power off alarm output 3A, 3B, 4A and 4B	1 Bit	R-CT--	[1.5] DPT_Alarm
22	Alarm text	14 Bytes	R-CT--	[16.0] DPT_String_ASCII
23	Disable front keyboard	1 Bit	-WC---	[1.2] DPT_Bool
24, 49, 74, 99, 124, 149, 174, 199	Valve on/off command – channel xA/B	1 Bit	-WCTU-	[1.1] DPT_Switch
24, 49, 74, 99, 124, 149, 174, 199	Valve continuous command – channel xA/B	1 Byte	-WCTU-	[5.1] DPT_Scaling
24, 74, 124, 174	Valve on/off heating command – channel xA	1 Bit	-WCTU-	[1.1] DPT_Switch
24, 74, 124, 174	Valve continuous heating command – channel xA	1 Byte	-WCTU-	[5.1] DPT_Scaling
49, 99, 149, 199	Valve on/off cooling command – channel xB	1 Bit	-WCTU-	[1.1] DPT_Switch
49, 99, 149, 199	Valve continuous cooling command – channel xB	1 Byte	-WCTU-	[5.1] DPT_Scaling
24, 49, 74, 99, 124, 149, 174, 199	On/off output command – channel xA/B	1 Bit	-WC---	[1.1] DPT_Switch
24, 49, 74, 99, 124, 149, 174, 199	Valve on/off status – channel xA/B	1 Bit	R-CT--	[1.1] DPT_Switch
24, 49, 74, 99, 124, 149, 174, 199	Valve continuous status – channel xA/B	1 Byte	R-CT--	[5.1] DPT_Scaling
24, 74, 124, 174	Valve on/off heating status – channel xA	1 Bit	R-CT--	[1.1] DPT_Switch
24, 74, 124, 174	Valve continuous heating status – channel xA	1 Byte	R-CT--	[5.1] DPT_Scaling
49, 99, 149, 199	Valve on/off cooling status – channel xB	1 Bit	R-CT--	[1.1] DPT_Switch
49, 99, 149, 199	Valve continuous cooling status – channel xB	1 Byte	R-CT--	[5.1] DPT_Scaling

Nr.	Object name di comunicazione	Dimensione	Flag	Tipo DataPoint
25, 50, 75, 100, 125, 150, 175, 200	Valve disable from bus – channel xA/B	1 Bit	-WC---	[1.3] DPT_Enable
25, 75, 125, 175	Heating valve disable from bus – channel xA	1 Bit	-WC---	[1.3] DPT_Enable
50, 100, 150, 200	Cooling valve disable from bus – channel xB	1 Bit	-WC---	[1.3] DPT_Enable
26, 51, 76, 101, 126, 151, 176, 201	Enable forced mode from bus – channel xA/B	1 Bit	-WC---	[1.3] DPT_Enable
26, 76, 126, 176	Enable heating forced mode from bus – channel xA	1 Bit	-WC---	[1.3] DPT_Enable
51, 101, 151, 201	Enable cooling forced mode from bus – channel xB	1 Bit	-WC---	[1.3] DPT_Enable
27, 52, 77, 102, 127, 152, 177, 202	Temperature control alarm – channel x - xA/B	1 Bit	-WC---	[1.5] DPT_Alarm
28, 53, 78, 103, 128, 153, 178, 203	Room temperature 1 (from bus) – channel x – xA/B	2 Bytes	-WCT--	[9.1] DPT_Value_Temp
29, 54, 79, 104, 129, 154, 179, 204	Room temperature 2 (from bus) – channel x – xA/B	2 Bytes	-WCT--	[9.1] DPT_Value_Temp
30, 55, 80, 105, 130, 155, 180, 205	Floor surface temperature (from bus) – channel x – xA/B	2 Bytes	-WCT--	[9.1] DPT_Value_Temp
31, 56, 81, 106, 131, 156, 181, 206	Anticondensation sensor (from bus) – channel x – xA/B	1 Bit	-WCT--	[1.5] DPT_Alarm
32, 57, 82, 107, 132, 157, 182, 207	Windows contact sensor (from bus) – channel x – xA/B	1 Bit	-WCT--	[1.19] DPT_Window_Door
33, 58, 83, 108, 133, 158, 183, 208	Presence sensor (from bus) – channel x – xA/B	1 Bit	-WCT--	[1.18] DPT_Occupancy
34, 59, 84, 109, 134, 159, 184, 209	HVAC mode in – channel x – xA/B	1 Byte	-WC---	[20.102] DPT_HVACMode
35, 60, 85, 110, 135, 160, 185, 210	HVAC manual mode – channel x – xA/B	1 Byte	-WC---	[20.102] DPT_HVACMode
36, 61, 86, 111, 136, 161, 186, 211	Chrono active status – channel x – xA/B	1 Bit	RWCTU-	[1.11] DPT_State
37, 62, 87, 112, 137, 162, 187, 212	HVAC mode out – channel x – xA/B	1 Byte	R-CT--	[20.102] DPT_HVACMode
38, 63, 88, 113, 138, 163, 188, 213	Actual setpoint – channel x – xA/B	2 Bytes	R-CT--	[9.1] DPT_Value_Temp
39, 64, 89, 114, 139, 164, 189, 214	Manual setpoint – channel x – xA/B	2 Bytes	RWCTU-	[9.1] DPT_Value_Temp
40, 65, 90, 115, 140, 165, 190, 215	Manual setpoint active status – channel x – xA/B	1 Bit	RWCTU-	[1.11] DPT_State
41, 66, 91, 116, 141, 166, 191, 216	Input setpoint – channel x – xA/B	2 Bytes	-WC---	[9.1] DPT_Value_Temp
41, 66, 91, 116, 141, 166, 191, 216	Comfort setpoint (heating) – channel x – xA/B	2 Bytes	RWCTU-	[9.1] DPT_Value_Temp
42, 67, 92, 117, 142, 167, 192, 217	Comfort setpoint (cooling) – channel x – xA/B	2 Bytes	RWCTU-	[9.1] DPT_Value_Temp
43, 68, 93, 118, 143, 168, 193, 218	Standby offset (heating) – channel x – xA/B	2 Bytes	RWCTU-	[9.2] DPT_Value_Tempd
43, 68, 93, 118, 143, 168, 193, 218	Standby setpoint (heating) – channel x – xA/B	2 Bytes	RWCTU-	[9.1] DPT_Value_Temp
44, 69, 94, 119, 144, 169, 194, 219	Standby offset (cooling) – channel x – xA/B	2 Bytes	RWCTU-	[9.2] DPT_Value_Tempd
44, 69, 94, 119, 144, 169, 194, 219	Standby setpoint (cooling) – channel x – xA/B	2 Bytes	RWCTU-	[9.1] DPT_Value_Temp
45, 70, 95, 120, 145, 170, 195, 220	Economy offset (heating) – channel x – xA/B	2 Bytes	RWCTU-	[9.2] DPT_Value_Tempd

Nr.	Object name di comunicazione	Dimensione	Flag	Tipo DataPoint
45, 70, 95, 120, 145, 170, 195, 220	Economy setpoint (heating) – channel x – xA/B	2 Bytes	RWCTU-	[9.1] DPT_Value_Temp
46, 71, 96, 121, 146, 171, 196, 221	Economy offset (cooling) – channel x – xA/B	2 Bytes	RWCTU-	[9.2] DPT_Value_Tempd
46, 71, 96, 121, 146, 171, 196, 221	Economy setpoint (cooling) – channel x – xA/B	2 Bytes	RWCTU-	[9.1] DPT_Value_Temp
47, 72, 97, 122, 147, 172, 197, 222	Building protection setpoint (heating) – channel x – xA/B	2 Bytes	RWCTU-	[9.1] DPT_Value_Temp
48, 73, 98, 123, 148, 173, 198, 223	Building protection setpoint (cooling) – channel x – xA/B	2 Bytes	RWCTU-	[9.1] DPT_Value_Temp
224, 229, 234, 239	Logic function X, Input 1	1 Bit	-WCTU-	[1.1] DPT_Switch
225, 230, 235, 240	Logic function X, Input 2	1 Bit	-WCTU-	[1.1] DPT_Switch
226, 231, 236, 241	Logic function X, Input 3	1 Bit	-WCTU-	[1.1] DPT_Switch
227, 232, 237, 242	Logic function X, Input 4	1 Bit	-WCTU-	[1.1] DPT_Switch
228, 233, 238, 243	Logic function X, Output	1 Bit	R-CT--	[1.1] DPT_Switch

8.2 Retentive communication objects

The communication objects listed in the table below retain their own state or value in a non-volatile memory even after a voltage failure on KNX bus.

Nr.	Object name di comunicazione	Dimensione	Flag	Tipo DataPoint	Stato O.C. in memoria ritentiva
0	Heating/cooling changeover command (2 pipes)	1 Bit	-WCTU-	[1.100] DPT_Heat_Cool	X
2, 4, 6, 8	Heating/cooling changeover command (4 pipes) – channel x	1 Bit	-WCTU-	[1.100] DPT_Heat_Cool	X
10	Enable general forced mode from bus	1 Bit	-WCT--	[1.3] DPT_Enable	X
25, 50, 75, 100, 125, 150, 175, 200	Valve disable from bus – channel xA/B	1 Bit	-WC---	[1.3] DPT_Enable	X
25, 75, 125, 175	Heating valve disable from bus – channel xA	1 Bit	-WC---	[1.3] DPT_Enable	X
50, 100, 150, 200	Cooling valve disable from bus – channel xA	1 Bit	-WC---	[1.3] DPT_Enable	X
26, 51, 76, 101, 126, 151, 176, 201	Enable forced mode from bus – channel xA/B	1 Bit	-WC---	[1.3] DPT_Enable	X
26, 76, 126, 176	Enable heating forced mode from bus – channel xA	1 Bit	-WC---	[1.3] DPT_Enable	X
51, 101, 151, 201	Enable cooling forced mode from bus – channel xB	1 Bit	-WC---	[1.3] DPT_Enable	X
35, 60, 85, 110, 135, 160, 185, 210	HVAC manual mode – channel x – xA/B	1 Byte	-WC---	[20.102] DPT_HVACMode	X
36, 61, 86, 111, 136, 161, 186, 211	Chrono active status – channel x – xA/B	1 Bit	RWCTU-	[1.11] DPT_State	X
40, 65, 90, 115, 140, 165, 190, 215	Manual setpoint active status – channel x – xA/B	1 Bit	RWCTU-	[1.11] DPT_State	X
41, 66, 91, 116, 141, 166, 191, 216	Input setpoint – channel x – xA/B	2 Bytes	-WC---	[9.1] DPT_Value_Temp	X
41, 66, 91, 116, 141, 166, 191, 216	Setpoint comfort (heating) - channel xA/B	2 Bytes	RWCTU-	[9.1] DPT_Value_Temp	X
42, 67, 92, 117, 142, 167, 192, 217	Comfort setpoint (heating) – channel x – xA/B	2 Bytes	RWCTU-	[9.1] DPT_Value_Temp	X
43, 68, 93, 118, 143, 168, 193, 218	Standby offset (heating) – channel x – xA/B	2 Bytes	RWCTU-	[9.2] DPT_Value_Tempd	X
43, 68, 93, 118, 143, 168, 193, 218	Standby setpoint (heating) – channel x – xA/B	2 Bytes	RWCTU-	[9.1] DPT_Value_Temp	X
44, 69, 94, 119, 144, 169, 194, 219	Standby offset (cooling) – channel x – xA/B	2 Bytes	RWCTU-	[9.2] DPT_Value_Tempd	X
44, 69, 94, 119, 144, 169, 194, 219	Standby setpoint (cooling) – channel x – xA/B	2 Bytes	RWCTU-	[9.1] DPT_Value_Temp	X
45, 70, 95, 120, 145, 170, 195, 220	Economy offset (heating) – channel x – xA/B	2 Bytes	RWCTU-	[9.2] DPT_Value_Tempd	X
45, 70, 95, 120, 145, 170, 195, 220	Economy setpoint (heating) – channel x – xA/B	2 Bytes	RWCTU-	[9.1] DPT_Value_Temp	X
46, 71, 96, 121, 146, 171, 196, 221	Economy offset (cooling) – channel x – xA/B	2 Bytes	RWCTU-	[9.2] DPT_Value_Tempd	X

Nr.	Object name di comunicazione	Dimensione	Flag	Tipo DataPoint	Stato O.C. in memoria ritentiva
46, 71, 96, 121, 146, 171, 196, 221	Economy setpoint (cooling) – channel x – xA/B	2 Bytes	RWCTU-	[9.1] DPT_Value_Temp	X
47, 72, 97, 122, 147, 172, 197, 222	Building protection setpoint (heating) – channel x – xA/B	2 Bytes	RWCTU-	[9.1] DPT_Value_Temp	X
48, 73, 98, 123, 148, 173, 198, 223	Building protection setpoint (cooling) – channel x – xA/B	2 Bytes	RWCTU-	[9.1] DPT_Value_Temp	X

8.3 Error indications

The communication object with index 22 – *Alarm text*, contains the code of the latest alarm detected or returned to normal. The following table shows the list of all error codes and descriptions.

Alarm code	Cause
General alarms	
A01	Technical alarm
A02	Communication alarm
A03	Thermal generator alarm
A04	Short-circuit alarm
A05	Power supply fault alarm channels 1A, 1B, 2A and 2B
A06	Power supply fault alarm channels 3A, 3B, 4A and 4B
Error code	Cause
Channel specific alarm	
E00, E15, E30, E45, E60, E75, E90, E105	Channel xA/B – Room temperature sensor 1 failure
E01, E16, E31, E46, E61, E76, E91, E106	Channel xA/B – Room temperature sensor 2 failure
E02, E17, E32, E47, E62, E77, E92, E107	Channel xA/B - Floor radiant temperature sensor failure
E03, E18, E33, E48, E63, E78, E93, E108	Channel xA/B – Room temperature sensor 1 timeout
E04, E19, E34, E49, E64, E79, E94, E109	Channel xA/B – Room temperature sensor 2 timeout
E05, E20, E35, E50, E65, E80, E95, E110	Channel xA/B – Timeout - Floor radiant temperature sensor
E06, E21, E36, E51, E66, E81, E96, E111	Channel xA/B – Temperature control alarm
E07, E22, E37, E52, E67, E82, E97, E112	Channel xA/B – Surface temperature alarm
E08, E23, E38, E53, E68, E83, E98, E113	Channel xA/B – Condensation alarm
E09, E24, E39, E54, E69, E84, E99, E114	Channel xA/B – Valve command timeout

8.4 Application examples

The following figures show some application examples of the actuator-controller EK-HE1-TP.

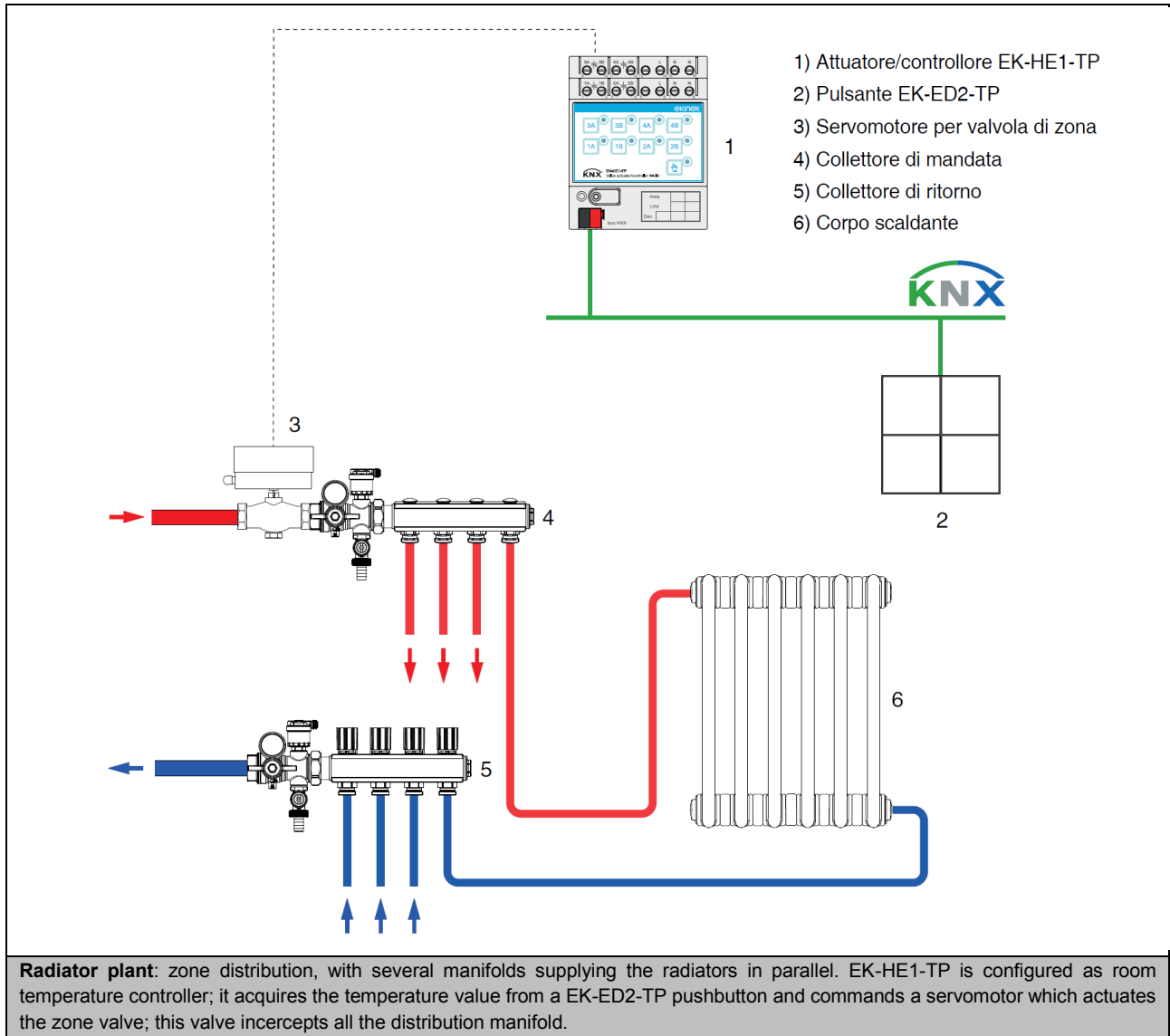

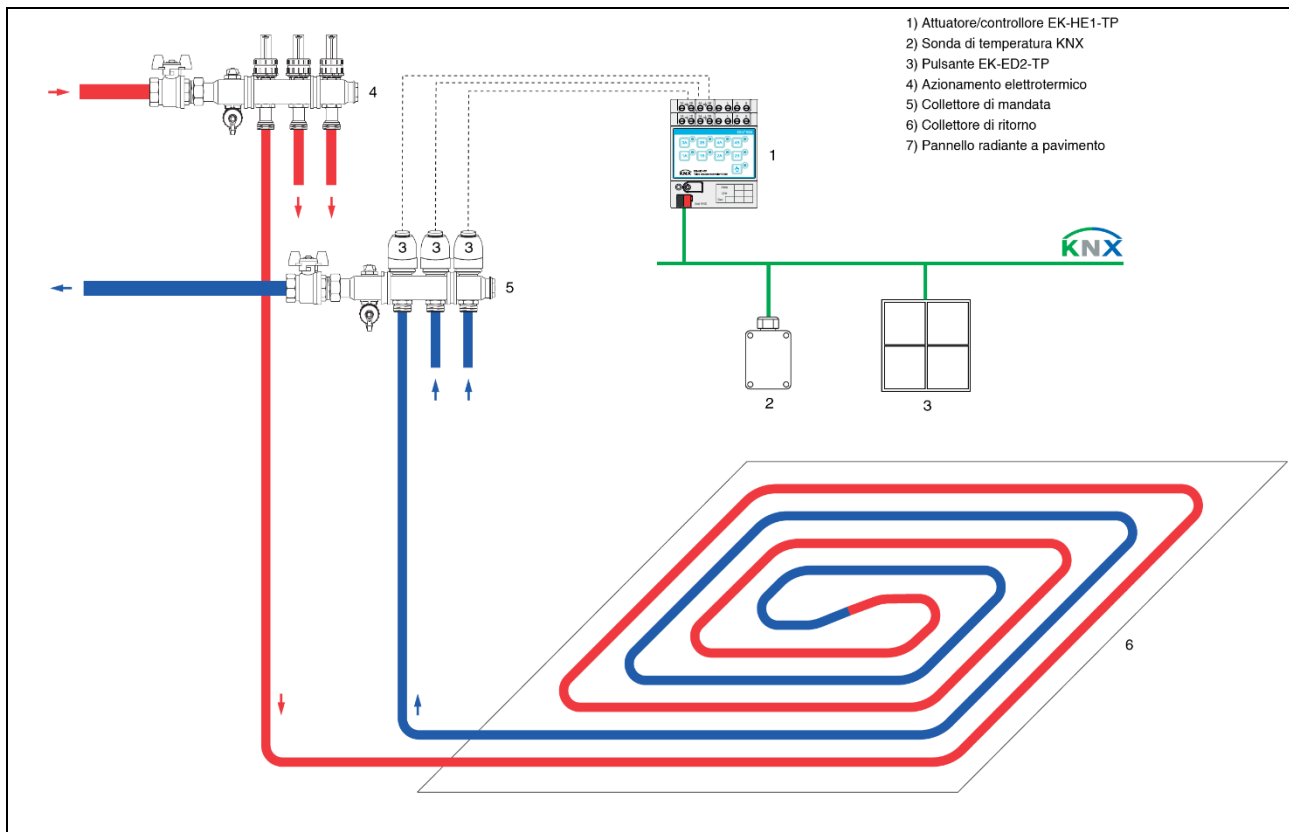

Floor radiant panel plant: it is made with distribution manifolds. EK-HE1-TP is configured as room temperature controller and it calculates a weighted average between the temperature value received from a EK-ED2-TP pushbutton and the temperature value received from a blind room temperature sensor. The device controls the electrothermal actuators which intercept the circuits in parallel.

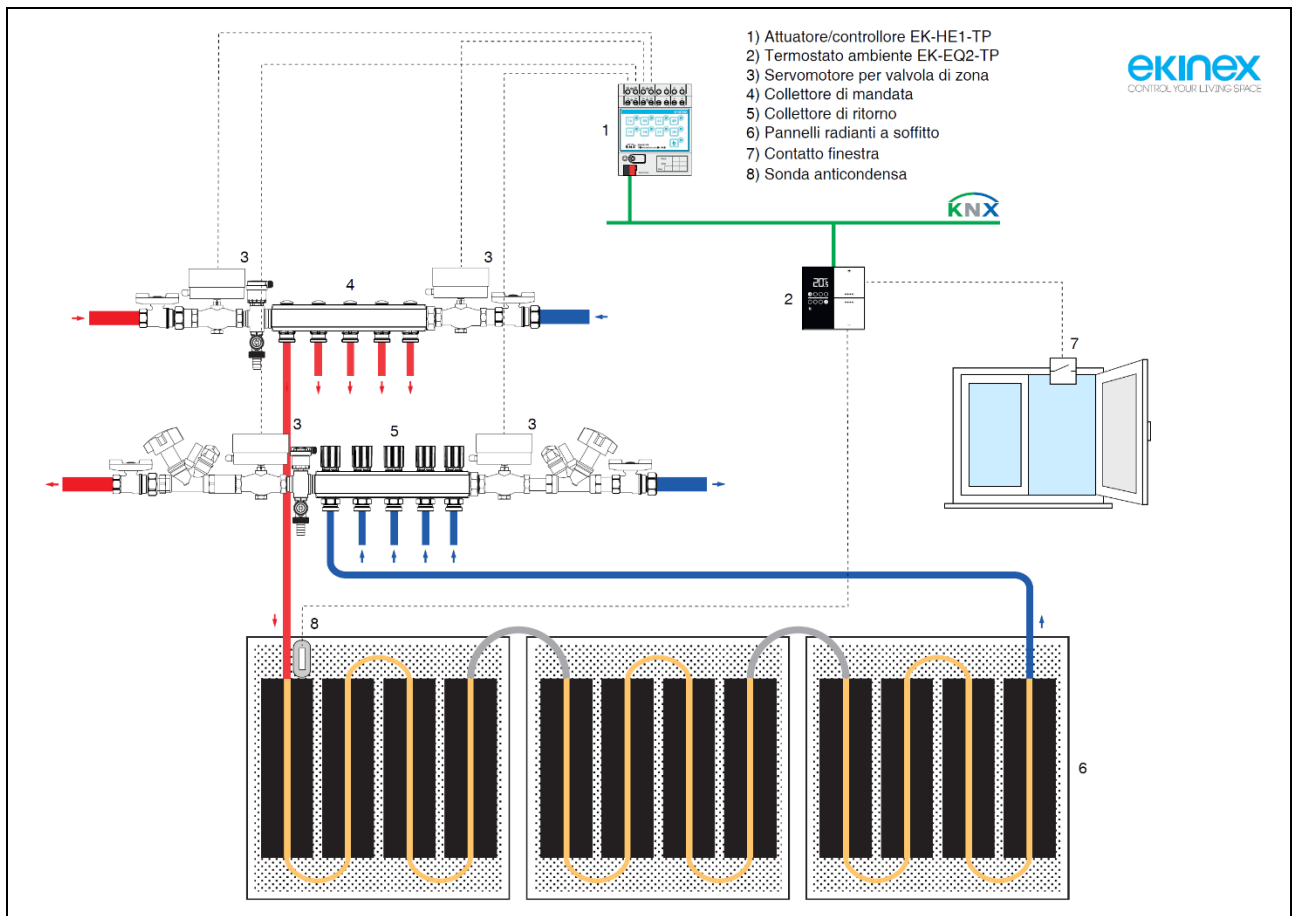

Ceiling radiant panel plant: EK-HE1-TP is configured as actuator (4 pipes) and is controlled by a EK-EQ2-TP room thermostat which automatically switches conduction mode according to the measured room temperature. The 4 servomotors are interlocked in couples in order to prevent hot and cool fluids from mixing together during changeover: for example, during heating to cooling changeover, the operating sequence completely closes the valves on the left side of the manifold (based on total time needed to fully open the servomotor); then, when the hot side is closed, the valves on the right side of the manifold are opened through their servomotors.

9 Warnings

- Installation, electrical connection, configuration and commissioning of the device can only be carried out by qualified personnel.
- Opening the housing of the device causes the immediate end of the warranty period.
- ekinex® KNX defective devices must be returned to the manufacturer at the following address:
SBS S.p.A. - Via Circonvallazione s/n, I-28010 Miasino (NO) Italy.

10 Other information

- This application manual is aimed at installers, system integrators and planners
- For further information on the product, please contact the ekinex® technical support at the e-mail address: support@ekinex.com or visit the website www.ekinex.com
- ekinex® is a registered trademark of SBS S.p.A.
- KNX® and ETS® are registered trademarks of KNX Association cvba, Brussels

© SBS S.p.A. 2016. The company reserves the right to make changes to this documentation without notice.